

# FireNET 2127/4127

## Analog Addressable Fire Alarm System

### Installation and Operation Manual



Hochiki America Corporation  
7051 Village Drive, Suite 100  
Buena Park, CA 90621-2268  
714.522.2246 Corporate Headquarters  
800.845.6692 Technical Support  
<http://www.hochiki.com>

Version 2.04- UL  
Created: 08/15/05  
Updated: August 2017

PN# 1700-09948

# Table of Contents

<b>Table of Contents</b> .....	<b>2</b>
<b>Prefix – Programming Compliance with UL864 9<sup>th</sup> Edition</b> .....	<b>6</b>
<b>Section 1 – Introduction</b> .....	<b>7</b>
1.1 Basic Features.....	7
1.2 System Devices and Equipment.....	8
1.2A FireNET Integrated Models.....	10
1.2B System Devices BOSCH.....	11
1.2C System Devices Silent Knight.....	12
1.2D System Devices Fike.....	13
1.2E System Devices NAPCO.....	14
1.2F System Devices VES.....	15
1.2.1 System Replacement Parts.....	16
1.3 Limitations of Fire Alarm Systems.....	17
1.4 Agency Listings, Approvals, Requirements.....	20
1.4.1 Federal Communications Commission (FCC).....	20
1.4.2 Underwriters Laboratories (UL).....	20
1.4.3 National Fire Protection Association (NFPA).....	20
1.4.4 New York City.....	21
<b>Section 2 – Control Panel Installation</b> .....	<b>22</b>
2.1 What’s in the Box?.....	22
2.2 Environmental Specifications.....	22
2.3 Control Panel Layout.....	23
2.3.1 Front Panel Layout, Standard Build.....	23
2.3.2 Front Panel Layout, Denver Door Build.....	24
2.3.3 Control Panel Annunciator, Control Unit and Power Supply Layout.....	25
2.4 Mounting the Control Panel.....	26
2.5 Wiring Specifications.....	26
2.5.1 Suggested Routing of AC Power.....	27
2.6 Battery Calculations.....	28
2.7 Electrical Ratings.....	30
2.8 Specifications.....	33
<b>Section 3 - Power Supply and Main Control Unit Connections</b> .....	<b>34</b>
3.1 AC Power Connection.....	34
3.2 Battery Connection.....	34
3.3 Auxiliary Power Connection.....	35
3.4 Notification Appliance Circuit Connection.....	37
3.5 Voltage Routing and Relay Output Connection.....	38
3.5.1 Voltage Routing Outputs.....	38
3.5.2 Relay Outputs.....	39
3.6 Digital Input Connection.....	40
3.7 Using a Printer.....	41
3.8 Computer / Programming Port Connections.....	41

<b>Section 4 – Expander Board Installation .....</b>	<b>42</b>
4.1 Compatible Expander Boards.....	42
4.2 General Installation of RS-485 Bus Devices.....	43
4.2.1 Wiring Distance and Mounting Locations.....	43
4.2.2 Addressing.....	44
4.2.3 Terminating.....	44
4.2.4 Power Connections .....	45
4.2.5 COMMS Connection.....	45
4.3 FN-4127-IO - Input / Output Board .....	46
4.3.1 Configuring Inputs .....	46
4.3.2 Configuring Outputs.....	47
4.3.3 LED Indicators .....	48
4.4 Reserved for Future Use .....	48
4.5 Reserved for Future Use .....	48
4.6 FN-4127-SLC – Dual SLC Loop Expander.....	49
4.6.1 Installation of the FN-4127-SLC .....	49
4.7 FN-LCD-S Serial Liquid Crystal Display Annunciator .....	50
4.7.1 Installation of the FN-LCD-S.....	50
<b>Section 5 – SLC Device Installation .....</b>	<b>53</b>
5.1 Compatible SLC Devices.....	53
5.2 Number of Devices .....	55
5.3 SLC Loop Wiring .....	55
5.3.1 Class B SLC Loop Wiring Distance .....	56
5.3.2 Class A SLC Loop Wiring Distance .....	58
5.4 Addressing Devices.....	60
5.4.1 Detector Addressing .....	62
5.4.2 4-S Module and AMS Addressing.....	62
5.4.3 Mini Module Addressing .....	63
5.5 Smoke and Heat Detector Wiring .....	64
5.6 Analog Duct Detector Wiring .....	65
5.6.1 DH98-A Analog Duct Detector.....	66
5.6.2 DH98-AR Analog Duct Detector with Relay.....	67
5.7 FRCME-4 Input Module Wiring.....	68
5.8 FRCME-S Mini Input Module (w/ Terminal Blocks).....	69
5.9 FRCME-P Mini Input Module (w/ Pigtails) .....	70
5.10 FRCME-M Mini Input Module (w/ Terminal Blocks).....	71
5.11 FRCMA / FRCMA-I Input Module .....	72
5.12 R2M Dual Relay Module Wiring.....	74
5.13 SOM Supervised Output Module .....	75
5.14 SOM-A / SOM-AI Supervised Class A Output Module .....	76
5.15 SOM-R Supervised Output Module (Preaction Sprinkler Systems) .....	77
5.16 CZM Conventional Zone Module .....	81
5.17 DIMM Dual Input Monitor Module .....	82
5.18 SCI Short Circuit Isolator Module .....	83
5.18.1 Class A Operation .....	84
5.18.2 Class B Operation .....	85
5.19 ASB & ASBL Analog Sounder Base .....	86
5.20 AMS Addressable Manual Pull-Station.....	87

<b>Section 6 - Network Connections</b> .....	<b>88</b>
6.1 Compatible Network Devices.....	88
6.1.1 FN-4127-NIC Network Interface Card .....	89
6.1.2 FN-LCD-N Network Liquid Crystal Display Annunciator .....	94
<b>Section 7 - Basic Front Panel Operations and Programming</b> .....	<b>96</b>
7.1 Operating Modes .....	97
7.1.1 Access Level 1 .....	97
7.1.2 Access Level 2 .....	97
7.1.3 Access Level 3 .....	97
7.2 Access Level 1 Operations.....	97
7.2.1 Performing a Lamp Test .....	97
7.2.2 More Fire Events .....	98
7.2.3 More Events .....	98
7.2.4 Menu Navigation (Up, Down, Left, Right Arrows, Enter / Exit Buttons).....	98
7.2.5 Help (?).....	98
7.3 Access Level 2 Operations.....	99
7.3.1 Entering Access Level 2 .....	99
7.3.2 Silencing an Alarm.....	99
7.3.3 Resounding an Alarm .....	99
7.3.4 Resetting an Alarm .....	100
7.3.5 Initiating a Fire Drill.....	100
7.3.6 Silence the Panel Sounder .....	100
7.4 Advanced Access Level 2 Operations .....	101
7.4.1 Access Level 2 Main Menu.....	101
7.4.2 Disablements.....	101
7.4.3 View Devices .....	103
7.4.4 Test Zones.....	103
7.4.5 Set System Time .....	104
7.5 Panel Operation.....	104
7.5.1 Fire Condition .....	104
7.5.2 Trouble Condition .....	105
7.5.3 Supervisory Condition.....	106
7.5.4 Pre-Alarm Condition .....	107
<b>Section 8 - Advanced Front Panel Operations and Programming (Access Level 3)</b> .....	<b>108</b>
8.1 Access Level Overview .....	108
8.1.1 Entering Access Level 3 .....	108
8.2 Access Level 3 Menu .....	109
8.2.1 Edit Configuration .....	109
8.2.2 Set Times .....	117
8.2.3 View Print Event Log .....	118
8.2.4 Print Configuration.....	119
8.2.5 System Disablements.....	119
8.2.6 Loop Data Test.....	120
<b>Section 9 - Reserved</b> .....	<b>121</b>
<b>Section 10 - Testing and Troubleshooting</b> .....	<b>122</b>

10.1 One Man Walk Test - TEST ZONES .....	122
10.2 View / Print Event Log .....	123
10.2.1 View Event Log.....	123
10.2.2 Print Event Log .....	124
10.2.3 Clear Event Log.....	125
10.3 Loop Data Test.....	126
10.4 Troubleshooting.....	128
<b>Section 11 - Installation Records .....</b>	<b>130</b>
11.1 SLC Loop Point Record.....	130
11.2 RS485 Bus Device Record.....	130
11.3 Network Node Device Record .....	130
<b>Appendix A - Compatible Devices.....</b>	<b>143</b>
A.1 Two-Wire Smoke Detectors .....	143
A.1.1 Two-Wire Smoke Detectors BOSCH.....	144
A.2 Reserved for Future Use.....	144
A.3 Compatible Notification Appliances.....	145
A.4 Compatible 24VDC Devices.....	150
A.4.1 Compatible 24VDC Devices BOSCH.....	151
A.5 Using the Bosch D9068 Dialer with FireNET .....	152
A.5.1 Using the Bosch D9068 Contact Dialer with FireNET (Diagram) .....	152
A.5.2 Programming FireNET for use with the Bosch D9068 Dialer .....	153
A.5.3 Installation notes when using the Bosch D9068 Dialer with FireNET.....	154
A.6 Using the FN-CTM City Tie module with FireNET.....	155
A.7 Using the FNV-MP with FireNET.....	156
A.8 Changing the FN-PS402 Power Supply to 240VAC operation.....	157
<b>Appendix B – Panel Door Label Drawing .....</b>	<b>158</b>
<b>Appendix C - WARRANTY .....</b>	<b>160</b>

## Prefix – Programming Compliance with UL864 9<sup>th</sup> Edition

<b>Notice to Users, Installers, Authorities Having Jurisdiction, and other involved parties</b>			
<b>This product incorporates field-programmable software. In order for the product to comply with the requirements in the Standard for Control Units and Accessories for Fire Alarm Systems, UL 864 9<sup>th</sup> Edition, certain programming features or options must be limited to specific values or not used at all as indicated below.</b>			
<b>Program Feature or Option</b>	<b>Permitted in UL 864? (Y/N)</b>	<b>Possible settings</b>	<b>Settings permitted in UL864</b>
AC Fail Delay	Yes	0 – 24 hours	1 – 3 hours
Alarm Verification	Yes	5 – 60 seconds	60 second setting
Disable Buzzer	Yes	Enable/Disable	Enable
Disable Ground Trouble	Yes	Enable/Disable	Enable
Set Buzzer Silence Access Level	Yes	1 or 2	2
“Waterflow Alarm” and “General Purpose” Device Type	No	0 – 120 seconds	0 seconds
Disable SOM-R	No	Enable/Disable	None
Sensors set to Supervisory	No	Fire / Supervisory	Fire

# Section 1 – Introduction

The FireNET 2127/4127 is an analog addressable fire alarm system that meets the requirements of UL 864 9<sup>th</sup> Edition.

## 1.1 Basic Features

---

- The basic FireNET 2127/4127 control panel includes two SLC (Signaling Line Circuit) loops. Each loop is capable of supporting 127 analog addressable points (can be any combination of sensors and modules) for a total of 254 analog addressable points on the basic panel. Two additional SLC loops can be added to the panel increasing the analog addressable point capacity to 508. When analog sounder bases are used, the upper addresses 128 – 254 are allocated to increase loop capacity to 254 analog addressable points. This doubles the analog addressable point capacity of the panel. The combination of analog addressable points derived from sensors, modules, and sounder bases cannot exceed 800 addresses and sub-addresses maximum.
- Up to 4.0 amps of power is available to drive the system, SLC loops, notification appliances, and auxiliary equipment.
- Four Class B notification appliance circuits rated at 2.5 amps each (see Section 2.7 and 2.8 for additional details regarding NAC circuit ratings).
- Five programmable Form C relays are built-in to the control panel.
- 500 network-wide zones for device and circuit grouping.
- Analog Smoke Detector Features:
  - Automatic Drift Compensation
  - Maintenance Alert
  - Adjustable Day/Night Sensitivity
  - Calibration checking meets sensitivity test requirements of NFPA 72.
- Auto-Learn utility identifies system devices, which makes initial system start-up easier.
- 8 line by 40 character graphic display provides the most intuitive operator interface in the industry (320 characters total).
- Help screens are available from the front panel and annunciator user interface to assist in programming and operation.
- 512 additional points can be added to the system using the FN4127-IO 16 channel input/output boards. Each of these points can be programmed individually to be an input or low current output. These points are for secondary use only.

## 1.2 System Devices and Equipment

---

The following boards, expanders and devices are available from Hochiki America Corp. to be used with the FireNET 2127/4127 analog addressable fire alarm system. For a complete description and installation instructions of each product, please see the appropriate section of this manual and the literature supplied with the device itself.

Model	Description
<b>Control Panels</b>	
FN-4127	Analog/Addressable Fire Alarm Control Panel (4 SLC Loop)
FN-2127	Analog/Addressable Fire Alarm Control Panel (2 SLC Loop)
<b>NOTE:</b> There are several ordering models (i.e. 2 loop, 4 loop, network options, 120/240VAC, colors, etc.). Hochiki America's order entry department will establish exact model and configuration at time of order. Different ordering models are also reflected on the FireNET product datasheets.	
<b>Control Panel Expanders</b>	
FN-4127-NIC	Network Interface Card
FN-4127-SLC	Dual SLC Loop Expander Card
FN-4127-IO	16 Channel Input Output Board
FN-CTM	City-Tie Module
FN-DAC	Digital Alarm Communicator/Transmitter
<b>Annunciators</b>	
FN-LCD-N	Network LCD Annunciator
FN-LCD-S	Serial LCD Annunciator
<b>SLC Loop Devices</b>	
ALK-V	Analog Photoelectric Smoke Sensor
ALK-V2	Analog Photoelectric Smoke Sensor
ALG-V	Analog Photoelectric Smoke Sensor
AIE-EA	Analog Ionization Smoke Sensor
ATG-EA	Analog Heat Sensor
ACA-V	Analog Photoelectric and Heat Multi Sensor
ATJ-EA	Fixed Temperature and Rate of Rise Heat Detector
ALN-V	Analog Photo Electric Smoke Detector
ACC-V	Analog Multi Criteria Detector Photo Electric & Heat Detector
YBN-NSA-4	4" Base for Analog Sensors
HSB-NSA-6	6" Base for Analog Sensors
SCI-B4	4" Short Circuit Base for Analog Sensors
SCI-B6	6" Short Circuit Base for Analog Sensors
DH98-A	Analog Duct Smoke Detector
DH98-AR	Analog Duct Smoke Detector w/Relay
DH99-A	Analog Duct Smoke Detector
DH99-AR	Analog Duct Smoke Detector w/Relay



MS-RA, MS-RA/R, MS-KA/R	Remote Test Station for DH98A & DH98AR
FRCME-4	Input Module 4" Box Mount
FRCME-S	Mini Input Module w/ Terminal Block
FRCME-P	Mini Input Module w/Pigtail Leads
FRCME-M	Mini Input Module w/ Terminal Block
FRCMA, FRCMA-I	Class A Input Module 4" Box Mount (FRCMA-I has built-in SCI)
SOM, SOM-A, SOM-AI	Supervised Output Module
R2ML, R2ML-I	Dual Relay Module, 2 amp @ 30VDC (R2ML-I has built-in SCI)
R2M	Dual Relay Module
R2MH, R2MH-I	Dual Relay Module, 8 amp @ 30VDC (R2MH-I has built-in SCI)
SCI	Short Circuit Isolator Module
DIMM	Dual Input Monitor Module
CZM	Conventional Zone Module
ASB	Analog Sounder Base
ASBL	Analog Sounder Base – Low Frequency
AMS/KL/LP	Addressable Manual Pull-Station
<b>Accessories</b>	
TCH-B100-NS	Hand-held Programmer
FN-ACC	Battery/Accessory Enclosure (houses up to 33AH size batteries)
FN-ETR	Enclosure Trim Ring for Panel Flush Mount

## 1.2A FireNET Integrated Models

The chart below depicts FireNET models pre-built with optional components

Hochiki America Panel PN Breakdown		
<b>FN -2 127 US00CS-120</b>		
		→ This is panel voltage
		→ This is panel Color & Style
		→ This is whether panel is expandable
		→ Feature 1 [Network / Dialer / 16 I/O]
		→ This is the Language
		→ This is the Device Range
		→ This is the number of loops on the product
		→ This is the product style
Option Ranges		
Option Type	Valid Entries	Description
Product Style	FN	FireNET
Loops	2	2 Loop Hochiki Protocol
	4	4 Loop Hochiki protocol
	LCD	0 Loop Hochiki protocol
	LCT	0 Loop Hochiki protocol w/ Trim ring
Device Range	127	127 Points
	N	Network Annunciator
	S	Serial Annunciator
Language	US	US English
Feature 1 Network Card, Dialer & 16 I/O	0	None
	1	Network Card
	2	Internal Dialer
	3	External Dialer
	5	External Dialer & Network Card
	6	Network Card & 16 I/O Card
Expandable	0	Non-Expandable
	E	Expandable
Color	R	Red
	C	Charcoal
	G	Gray
Style	S	Standard
	D	Plexi Window
	P	Printer
	DP	Plexi Window & Printer
	N	Plexi Window New York Model
	NP	Plexi Window & Printer New York Model
Voltage	024	24 Volts
	120	110 Volts
	220	220 Volts

## 1.2B System Devices BOSCH

---

The following boards, expanders and devices are available from BOSCH to be used with the FireNET 2127/4127 analog addressable fire alarm system. For a complete description and installation instructions of each product, please see the appropriate section of this manual and the literature supplied with the device itself.

Model	Description
<b>Control Panels</b>	
FN-4127 FN-2127	Analog/Addressable Fire Alarm Control Panel (2 SLC Loop, expandable to 4 SLC Loop)
<p>NOTE: There are several ordering models (i.e. 2 loop, 4 loop, network options, 120/240VAC, colors, etc.). Bosch's order entry department will establish exact model and configuration at time of order. Different ordering models are also reflected on the FireNET product datasheets.</p>	
<b>SLC Loop Devices</b>	
D323A	Analog Photoelectric Smoke Sensor
D324A	Analog Ionization Smoke Sensor
D322A	Analog Heat Sensor
D336A	4" Base for Analog Sensors
D321A	6" Base for Analog Sensors
D331A	Analog Duct Smoke Detector
D332A	Analog Duct Smoke Detector w/Relay
D326A	Input Module 4" Box Mount
D339A	Mini Input Module w/ Terminal Block
D327A	Supervised Output Module
D335A	Dual Relay Module
D333A	Short Circuit Isolator Module
<b>Accessories</b>	
D5070	Hand-held Programmer

## 1.2C System Devices Silent Knight

---

The following devices are available from Silent Knight to be used with the FireNET 2127/4127 analog addressable fire alarm system. For a complete description and installation instructions of each product, please see the appropriate section of this manual and the literature supplied with the device itself.

<b>Model</b>	<b>Description</b>
<b>SLC Loop Devices</b>	
SD505-APS	Analog Photoelectric Smoke Sensor
SD505-AIS	Analog Ionization Smoke Sensor
SD505-AHS	Analog Heat Sensor
SD505-4AB	4" Base for Analog Sensors
SD505-6AB	6" Base for Analog Sensors
SD505-DUCT	Analog Duct Smoke Detector
<b>Accessories</b>	
SD505-DTS-K	Remote Test Switch

## 1.2D System Devices Fike

---

The following devices are available from Fike to be used with the FireNET 2127/4127 analog addressable fire alarm system. For a complete description and installation instructions of each product, please see the appropriate section of this manual and the literature supplied with the device itself.

Model	Description
<b>SLC Loop Devices</b>	
63-1021	Analog Photoelectric Smoke Sensor
67-1032	Analog Ionization Smoke Sensor
60-1028	Analog Heat Sensor
63-1020	4" Base for Analog Sensors
63-1023	6" Base for Analog Sensors
63-028/63-029	Analog Duct Smoke Detector
55-019/55-020	Fast Response Contact Monitor Module
55-023	Dual Relay Module
55-021	Supervised Output Module

NOTE: The 55-019 has been tested to UL 864 8<sup>th</sup> edition. However, the 55-019 will operate with the 9<sup>th</sup> edition listed FireNET Fire Alarm Control panel. Therefore, it may be used in panel retrofit applications, subject to approval by your AHJ.

## 1.2E System Devices NAPCO

---

The following devices are available from NAPCO to be used with the FireNET 2127/4127 analog addressable fire alarm system. For a complete description and installation instructions of each product, please see the appropriate section of this manual and the literature supplied with the device itself.

Model	Description
<b>SLC Loop Devices</b>	
FWC-FSLC-SMK	Analog Photoelectric Smoke Sensor
FWC-FSLC-HEAT	Analog Heat Sensor
FWC-FSLC-SMK4B	4" Base for Analog Sensors
FWC-FSLC-SMK6B	6" Base for Analog Sensors
FWC-FSLC-DUCT	Analog Duct Smoke Detector
FWC-FSLC-EZM1	Fast Response Contact Monitor Module
FWC-FSLC-EZM1B	Fast Response Mini Contact Monitor Module
FWC-FSLC-EZM2	Dual Input Monitor Module
FWC-FSLC-RM2	Dual Relay Module
FWC-FSLC-SOM1	Supervised Output Module
FWC-FSLC- PULL	Addressable Manual Pull Station
FWC-FSLC-ISO	Short Circuit Isolator Module

NOTE: The FWC-FSLC-EZM1 has been tested to UL 864 8<sup>th</sup> edition. However, FWC-FSLC-EZM1 will operate with the 9<sup>th</sup> edition listed FireNET Fire Alarm Control panel. Therefore, it may be used in panel retrofit applications, subject to approval by your AHJ

## 1.2F System Devices VES

The following devices are available from VES to be used with the FireNET 2127/4127 analog addressable fire alarm system. For a complete description and installation instructions of each product, please see the appropriate section of this manual and the literature supplied with the device itself.

Model	Description
<b>SLC Loop Devices</b>	
VF2002	Analog Photoelectric Smoke Sensor
VF2005-00	Analog Photoelectric Smoke Sensor
VF2001	Analog Ionization Smoke Sensor
VF2003	Analog Heat Sensor
VF2008	Multi Criteria Sensor
VF7001	4" Base for Analog Sensors
VF7002	6" Base for Analog Sensors
VF7008	Addressable Sounder Base
VF5001	Analog Duct Smoke Detector
VF5002	Analog Duct Smoke Detector w/Relay
VF6001	Fast Response Contact Monitor Module
VF6002	Fast Response Contact Monitor Module
VF6020-00	Fast Response Contact Monitor Module
VF6021-00	Fast Response Contact Monitor Module
VF6024-00	Fast Response Mini Contact Monitor Module
VF6007	Dual Input Monitor Module
VF6005	Dual Relay Module
VF6052-00	Dual Relay Module
VF6053-00	Dual Relay Module w/Short Circuit Isolator
VF6054-00	Dual Relay Module
VF6055-00	Dual Relay Module
VF6004	Supervised Output Module
VF6011	Conventional Zone Module
VF3029-10	Addressable Manual Pull Station
VF6003	Short Circuit Isolator Module

NOTE: The VF6002 has been tested to UL 864 8<sup>th</sup> edition. However, VF6002 will operate with the 9<sup>th</sup> edition listed FireNET Fire Alarm Control panel. Therefore, it may be used in panel retrofit applications, subject to approval by your AHJ

## 1.2.1 System Replacement Parts

Control Panel Repair / Replacement Parts	
FN-4127-BO	FireNET 4127 Control Unit Board Only (K6002)
FN-4127-CPA-BO	FireNET 4127 Panel Annunciator Board Only (K6001)
FN-PS4	FireNET 4 Amp Power Supply (UL864 8 <sup>th</sup> Edition Compliant)
FN-PS402*	FireNET 4 Amp Power Supply (UL864 9 <sup>th</sup> Edition Compliant)
FN-ENC	FireNET Enclosure Complete
FN-ENC-DO	FireNET Enclosure Door Only
FN-ENC-BC	FireNET Enclosure Back-Can Only
FN-PMP	FireNET Panel Mounting Plate
FN-PBS	FireNET Panel Bonding Strap
FN-PGB	FireNET Panel Grounding Block
FN-EOL	FireNET Panel EOLR (package)
FN-STO	FireNET Panel Standoffs (for panel covers)
FN-PRC	FireNET Panel Ribbon Cables (package)
FN-FUS	FireNET Main AC Input Fuse
FN-FUS-BATT	FireNET Battery Input Fuse
FN-BLJ	FireNET Battery Leads & Jumper
FN-MAN	FireNET Installation Manual
FN-PDL	FireNET Panel Door Label
FN-LSW	Loop Explorer Software CD
FN-X187	Programming Cable (Standard)
FN-S187	Programming Cable (Jacketed)
FN-SKDK	Spare Keys for Door Keyswitch
FN-SKCK	Spare Keys for Controls Keyswitch
FN-ECK	Enable Controls Keyswitch
FN-BLE	Battery Leads for Accessory Enclosure (extended length 3.28ft)
FN-LCD-N-ETR	Enclosure Trim Ring for Network Annunciator Flush Mount
FN-LCD-N-BB	Network Annunciator Back-box
FN-LCD-N-CPA-BO	Network Annunciator Annunciator Board Only (K6001 R version)
FN-LCD-N-BO	Network Annunciator Control Unit Board Only (K6007)
FN-LCD-S-BO	Serial Annunciator Control Unit Board Only (K6017)
FN-LCD-S-BB	Serial Annunciator Back-box
FN-EBS	Expansion Boards Standoffs (SLC board & I/O board stacking)
FN-ENC-DD	Denver Door Enclosure Front Door, including clear window
FN-CB-DD	Denver Door Circuit Board Mounting Plate
FN-ENC-BC-DD	Denver Door Enclosure Back-Can Only
FN-KEY-DD	CAT-30 Enclosure Key and Lock for FireNET and FireNET Denver Door version
FN-KEY-NY	Special NYC Lock Assembly
FN-S-DD	Access Level 2 Switch for Denver Door Build

\*NOTE: 240VAC option available



## 1.3 Limitations of Fire Alarm Systems

---

Follow Recommended Installation Guidelines: To achieve early fire detection, fire detection sensors should be installed in all rooms and areas of a house, apartment, or building in accordance with the recommendations of the National Fire Protection Association Standard 72 (NFPA 72), manufacturer's recommendations, state and local codes, and the recommendations contained in Guide for the Proper Use of System Smoke Detectors, which is made available at no charge to all installing dealers. Generally, the standards and recommendations include the following (but installers should refer to the specific guidelines above before installing):

- Sleeping Rooms: Smoke detectors should be installed in every sleeping room.
- Hallways: More than one smoke detector should be installed in a hallway if it is more than 30 feet long.
- At least Two Smoke Detectors: There should never be less than two smoke detectors per apartment or residence.
- Smoke Detectors in Alarm, Electrical, or Phone Locations: Smoke detectors should be located in any room where an alarm control is located or an alarm control connects to an electrical source or phone line. If detectors are not so located, a fire within the room could prevent the alarm control from reporting a fire.
- Notification Systems: All fire alarm systems require notification devices, including sirens, bells, horns, and/or strobes. In residential applications, each automatic alarm initiating device when activated should cause the operation of alarm notification device that should be clearly audible in all bedrooms over ambient or background noise levels (at least 15dB above noise) with all intervening doors closed.
- Alarm in Every Bedroom and Level of Residence: A smoke detector with an integral sounder (smoke alarm) should be located in every bedroom and an additional notification device should be located on each level of a residence.
- Maintenance: A maintenance agreement should be arranged through the local manufacturer's representative and maintenance should be performed annually by authorized personnel only. To keep a fire alarm system in excellent working order, ongoing maintenance is required per the manufacturer's recommendations and UL and NFPA standards. At a minimum the requirements of Chapter 7 of NFPA 72 (1999) shall be followed.
- Test Weekly: The alarm system should be tested weekly to make sure all sensors and transmitters are working properly. The most common cause of an alarm system not functioning when a fire occurs is inadequate maintenance.

Alarms Cannot Guarantee Warning or Protection: Fire alarm system cannot guarantee warning or protection against fire in every potential situation. A study by the Federal Emergency Management Agency (an agency of the United States government) indicated that smoke detectors may not go off or give early warning in as many as 35% of all fires.

Limitation on Fire Alarm Effectiveness: A fire alarm system may not provide timely or adequate warning, or simply may not function, for a variety of reasons. For example:

- No Detection: Particles of combustion or smoke from a developing fire may not reach the sensing chambers of smoke detectors because:

1. **Barriers** (such as closed or partially closed doors, walls, or chimneys) may inhibit particle or smoke flow.
  2. Smoke particles may become **cold, stratify, or not reach** the ceiling or upper walls where detectors are located.
  3. Smoke particles may be **blown away** from detectors by air outlets.
  4. Smoke particles may be **drawn into air returns** before reaching the detector.
- **No Multi-Floor Detection:** In general, smoke detectors on one level of a structure cannot be expected to sense fires developing on another level.
  - **Insufficient Smoke:** The amount of smoke present may be insufficient to alarm smoke detectors. Smoke detectors are designed to alarm, at various levels of smoke density. If such density levels are not created by a developing fire at the location of the detector, the detector will not go into alarm.
  - **Smoldering vs. Flaming Fires:** Smoke detectors, even when working properly, have sensing limitations. Detectors that have photoelectric sensing chambers tend to detect smoldering fires better than flaming fires, which have little visible smoke. Detectors that have ionizing-type sensing chambers tend to detect fast flaming fires better than smoldering fires. Because fires develop in different ways and are often unpredictable in their growth, neither type of detector is necessarily best and a given type of detector may not provide adequate warning of a fire.
  - **False Alarms and Pre-Fire Disconnection:** Smoke detectors are subject to false alarms and nuisance alarms and may have been disconnected by users. For example, a smoke detector located in or near a kitchen may go into nuisance alarm during normal operation of kitchen appliances. In addition, dusty or steamy environments may cause a smoke detector to falsely alarm. If the location of a smoke detector causes an abundance of false alarms or nuisance alarms, do not disconnect the smoke detector, call a professional to analyze the situation and recommend a solution.
  - **Fast Fires and Explosions:** Smoke detectors cannot be expected to provide adequate warning of fires caused by arson and children playing with matches (especially within bedrooms), smoking in bed, violent explosions (caused by escaping gas, improper storage of flammable materials, etc.).
  - **Heat Detectors:** Heat detectors do not sense particles of combustion and are designed to alarm only when heat on their sensors increases at a predetermined rate or reaches a predetermined level. Heat detectors are designed to protect property, not life.

- Unheeded Warning: Warning devices (including horns, sirens, and bells) may not alert people or wake up sleepers who are located on the other side of closed or partially open doors. A warning device that activates on a different floor or level of a dwelling or structure is less likely to awaken or alert people. Even persons who are aware may not notice the warning if the alarm is muffled by noise from a stereo, radio, air conditioner or other appliance, or by passing traffic. Audible warning devices may not alert the hearing impaired (strobes or other devices should be provided to warn these people). Any warning device may fail to alert people with a disability, deep sleepers, people who have recently used alcohol or drugs, or people on medication or sleeping pills.
  - Strobes: Strobes can under certain circumstances, cause seizures in people with conditions such as epilepsy.
  - Drills: Studies have shown that certain people, even when they hear a fire alarm signal, do not respond or comprehend the meaning of the signal. It is the property owner's responsibility to conduct fire drills and other training exercises to make people aware of fire alarm signals and instruct on the proper reaction to alarm signals.
  - Hearing Loss: In rare instances, the sounding of a warning device can cause temporary or permanent hearing loss.
- Telephone Transmissions Problems: Telephone lines needed to transmit alarm signals from a premises to a central station may be out of service or temporarily out of service. For added protection against telephone line failure, backup radio transmission systems are recommended.
- System Failure With Age or Lack of Maintenance: System components, though designed to last many years, can fail at any time. As a precautionary measure, it is recommended that smoke detectors be checked, maintained, and replaced per manufacturer's recommendations.
- Electrical Power Problems: System components will not work without electrical power. If system batteries are not serviced or replaced regularly, they may not provide battery backup when AC power fails.
- High Air Velocity or Dusty or Dirty Environments: Environments with high air velocity or that are dusty or dirty require more frequent maintenance.

Importance of Maintenance: In general, fire alarm systems and devices will not work without power and will not function properly unless they are maintained and tested regularly.

Alarm is Not Substitute for Insurance: While installing a fire alarm system may make the owner eligible for a lower insurance rate, an alarm system is not a substitute for insurance. Property owners should continue to act prudently in protecting the premises and the people in their premises and should properly insure life and property and buy sufficient amounts of liability insurance to meet their needs.

## ***1.4 Agency Listings, Approvals, Requirements***

---

### **1.4.1 Federal Communications Commission (FCC)**

The FireNET 2127/4127 has been verified to comply with FCC Rules Part 15, Class A Operation is subject to the following conditions:

1. This device may not cause radio interference.
2. This device must accept any interference received, including any that may cause undesired operation.

### **1.4.2 Underwriters Laboratories (UL)**

The FireNET 2127/4127 is UL864 9<sup>th</sup> Edition listed and is suitable for use as a commercial protected premises control unit as follows:

- Local signaling unit
- Types of signaling services are automatic, manual, waterflow, & sprinkler supervisory.
- Style 4, 6, or 7 for Signaling Line Circuits
- Style Y for Notification Appliance Circuits
- Non-coded signaling
- Central Station Service – DACT type (protected premise)
- Remote Station Service – DACT type (protected premise)
- Proprietary Service – DACT type (protected premise)\*
- Auxiliary Service – local energy type (protected premise)

\*When used with the Bosch D6600 Digital Alarm Communicator Receiver.

### **1.4.3 National Fire Protection Association (NFPA)**

Install and configure the FireNET system in accordance with NFPA 72 and 13.

All field wiring must be installed in accordance with NFPA 70 National Electric Code (Article 760).

#### **1.4.4 New York City**

New York City Fire Department Approval Certificate #6171

- All uses, configurations, arrangements and functions, application and installation shall comply with the provisions of New York City Construction codes, specifically Building Code Chapter 9 & Appendix Q section BC Q106, and New York City Electrical Code. Further, the installation shall be in accordance applicable provisions of New York City Fire Code, manufacturer's recommendations and UL Standard 864.

## Section 2 – Control Panel Installation

### 2.1 What's in the Box?

---

The FireNET 2127/4127 control panel includes the following components and hardware:

- ❑ Control panel cabinet with hinged door.
- ❑ Power supply module pre-mounted in cabinet
- ❑ Control panel annunciator & RS232 interface pre-mounted in cabinet
- ❑ Main control unit pre-mounted in cabinet.
- ❑ Two keys for the cabinet lock and two keys for the Enable Controls keyswitch. *Note that the Denver Door build does not include keys for the Enable Controls keyswitch.*
- ❑ (2) 10k ohm EOL resistors PN# 0400-01046, (4 or 8) zero ohm jumpers PN# 0400-01025, (1) 1N4004S diode PN# 0400-01024, and (4) EOLD devices PN# 0400-1023.
- ❑ Battery jumper for series connection of 2 – 12 volt batteries.
- ❑ Installation Manual (PN# 1700-09948)

### 2.2 Environmental Specifications

---

The FireNET 2127/4127 main control panel should be installed in locations where it will NOT be exposed to temperatures outside the range of 32° F – 120°F or humidity outside the range of 10%-85% non-condensing.

The FireNET 2127/4127 control panel must be installed so that it is not subjected to damage by water and condensation. AVOID mounting the control panel cabinet directly on exterior masonry walls, in areas subject to plumbing leaks, in areas subject to splash from sprinkler test valves, or in high humidity areas.

The FireNET control panel is intended for installation in indoor environments in a dry location.

## 2.3 Control Panel Layout

### 2.3.1 Front Panel Layout, Standard Build

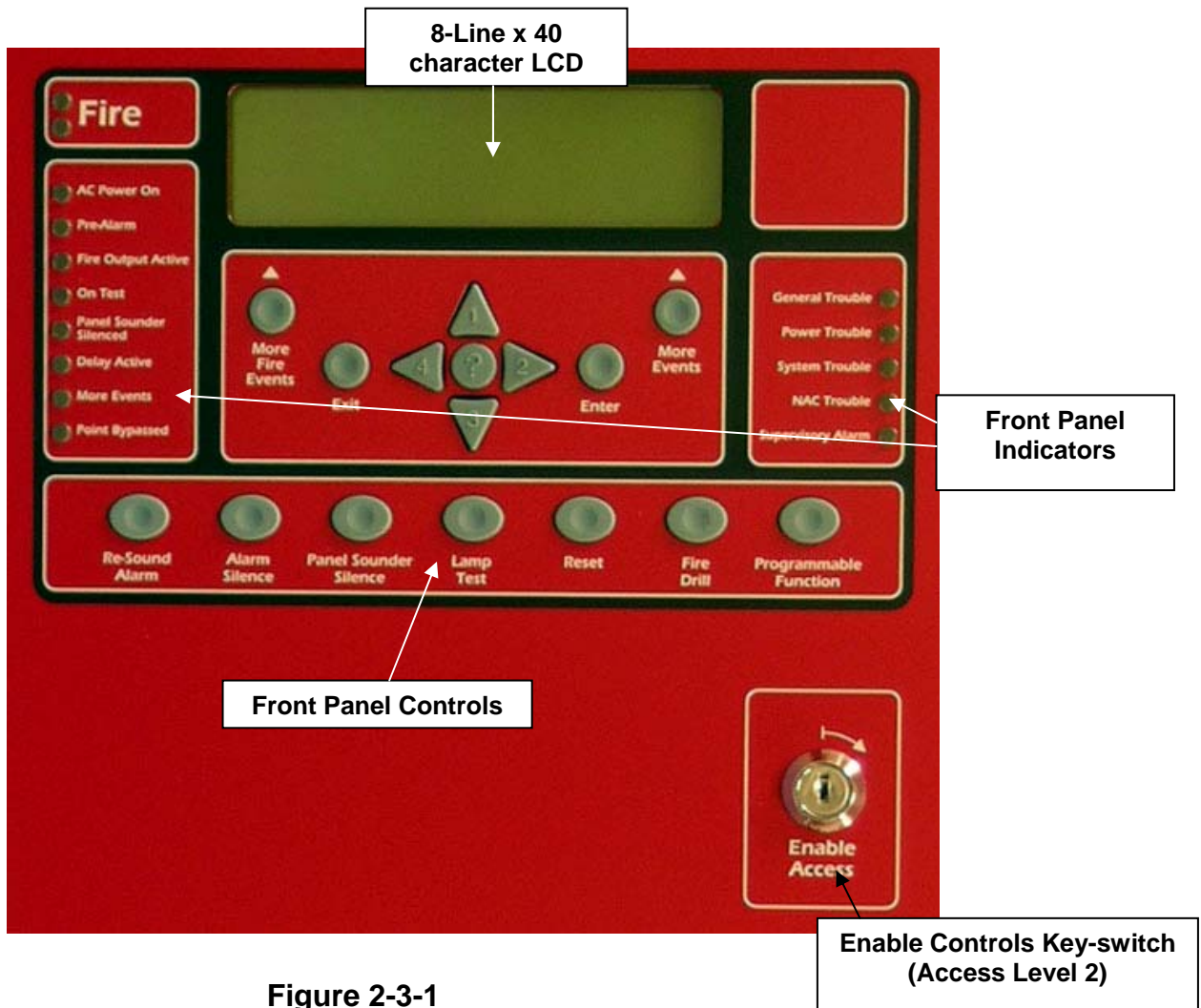

Figure 2-3-1



### 2.3.2 Front Panel Layout, Denver Door Build

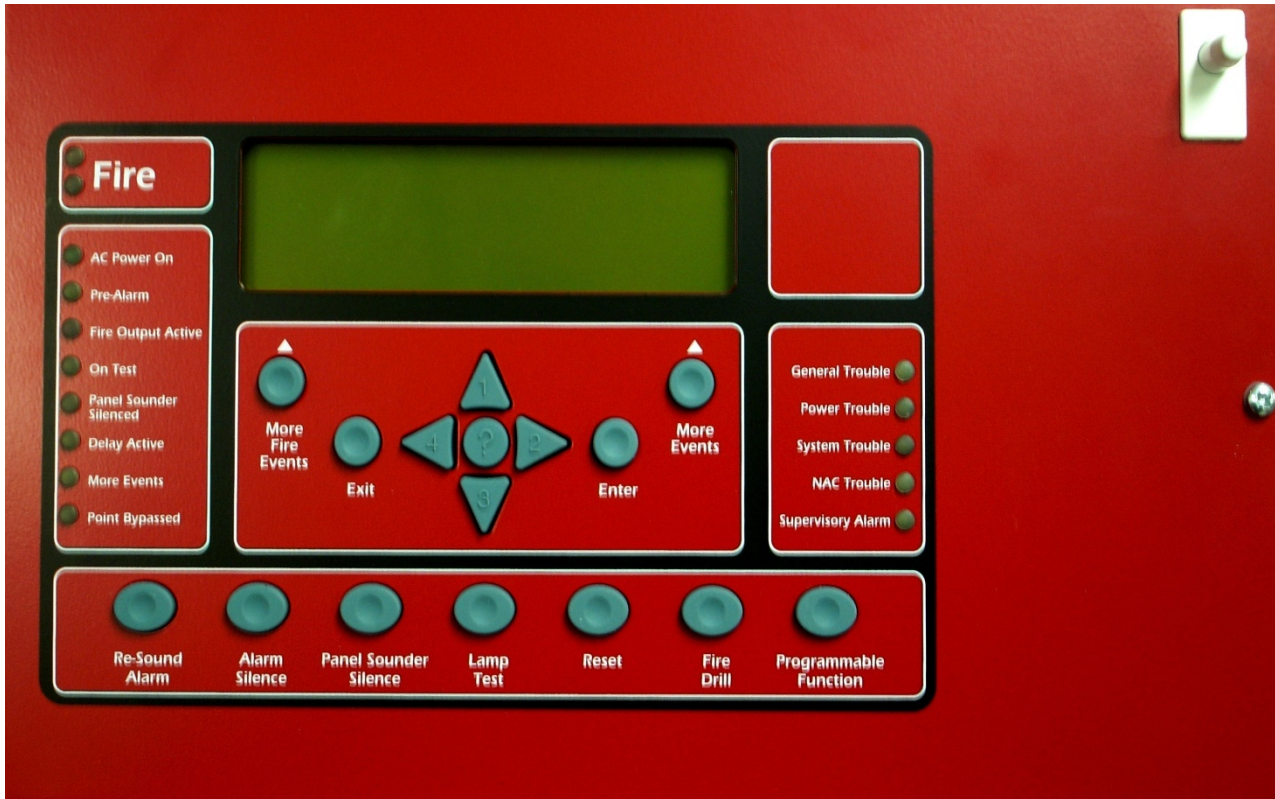

Figure 2-3-2

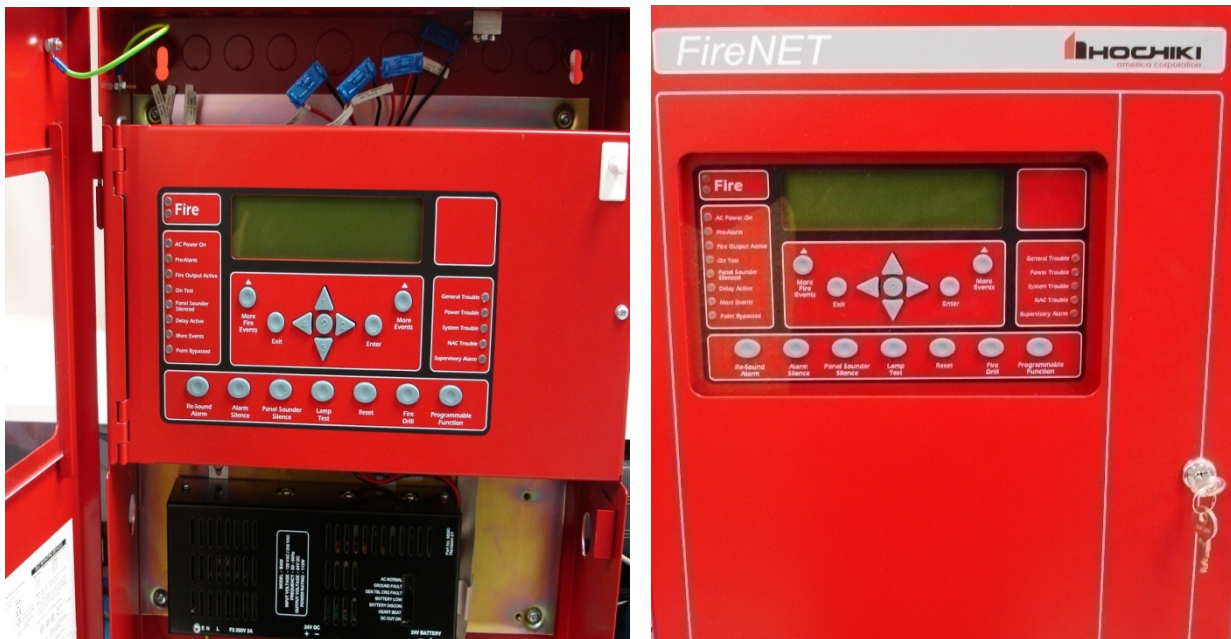
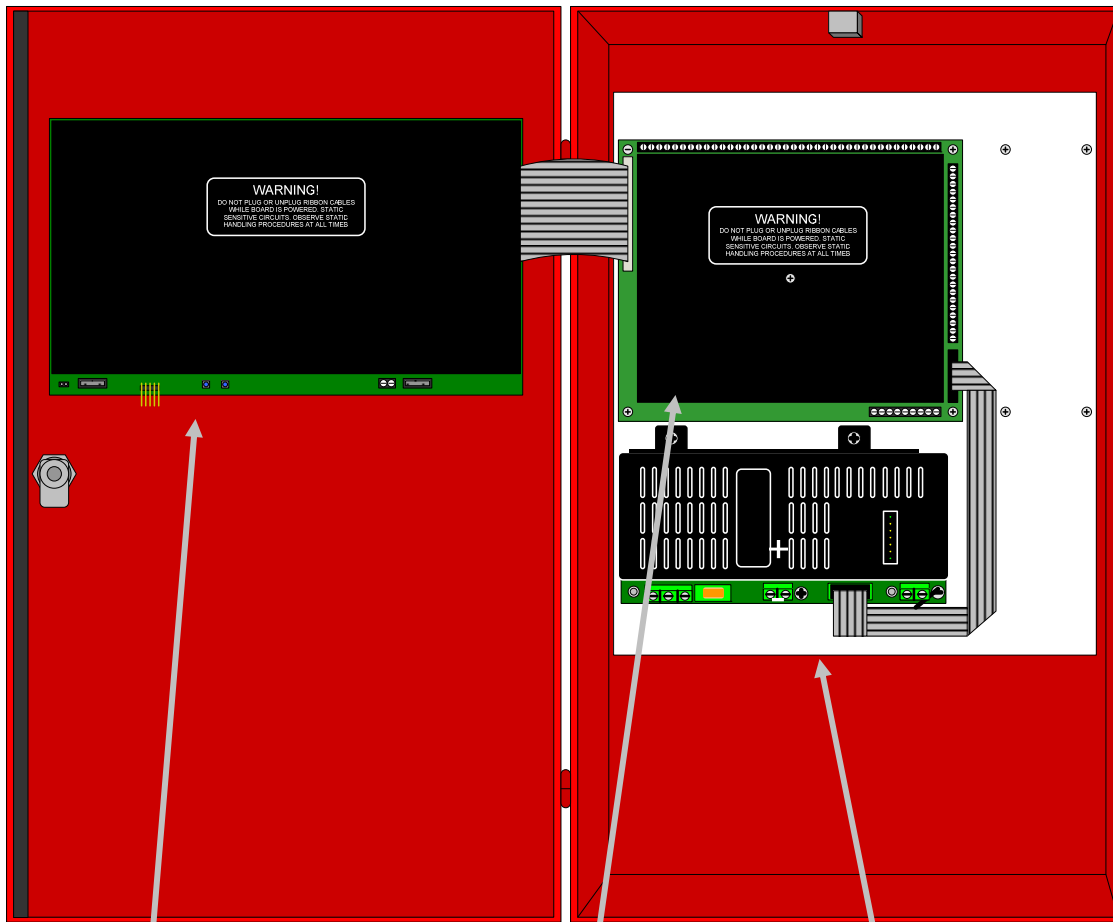

Figure 2-3-2a



## 2.3.3 Control Panel Annunciator, Control Unit and Power Supply Layout



### Control Panel Annunciator & RS 232 Interface

- Printer Connection
- PC Connection
- Front Panel Controls

### Main Control Unit

- SLC Loops
- Programmable Relays
- Notification Appliance Circuits
- Programmable Outputs
- Remote Control and Aux Inputs
- Expansion Board Connections
- Network Connections
- Aux Power Output

### Power Supply Module

- AC Power Connection
- Battery Connection

Figure 2-3-3

## ***2.4 Mounting the Control Panel***

---

Consult the environmental specifications listed in Section 2.2 to determine a suitable location to mount the FireNET 2127/4127 main control panel.

The panel should be mounted so that it is accessible to service personnel and located in a secure area.

Do not mount directly to a concrete wall. Use a suitable standoff material such as plywood to keep condensation away from the control panel.

## ***2.5 Wiring Specifications***

---

Care should be taken when wiring the system to avoid situations that would contribute to inducing electrical noise from one wire to another. Induced noise can interfere with telephone communications or cause erratic system operation. Follow these guidelines to plan your system wiring prior to installation.

- Route high and low voltage wiring separately. Maintain a minimum 2" separation between high and low voltage wiring throughout the building.
- Route control panel wiring around the perimeter of the enclosure. A minimum .25" separation is required between high and low voltage wiring.
- Identify which group each wire or cable is associated with from the list below. Isolate each groups wiring as much as possible. Avoid running a single multi-conductor cable for multiple groups of conductors.
  - AC Power - Main Power Supply
  - Notification Appliances
  - SLC Circuits
  - Relay Outputs
  - Voltage Outputs
  - Remote Control and Auxiliary Inputs
  - Network Wiring (Shielded wire required)
  - RS485 Bus Wiring (Shielded wire required)
- Keep wiring from different groups separated as much as possible. If you must share the same conduit with different conductor groups consider using shielded cable.
- If shielded cable is used terminate the shield to the earth ground terminal block in the main control panel and leave open at field side of cable. Do not ground at both ends of cable.
- All terminals on the FireNET control can accept wire gauges from 22AWG and 14AWG.

## 2.5.1 Suggested Routing of AC Power

Route the AC input power wiring as outlined below. Follow recommendations outlined in section 2.5 regarding the separation of high and low voltage wiring.

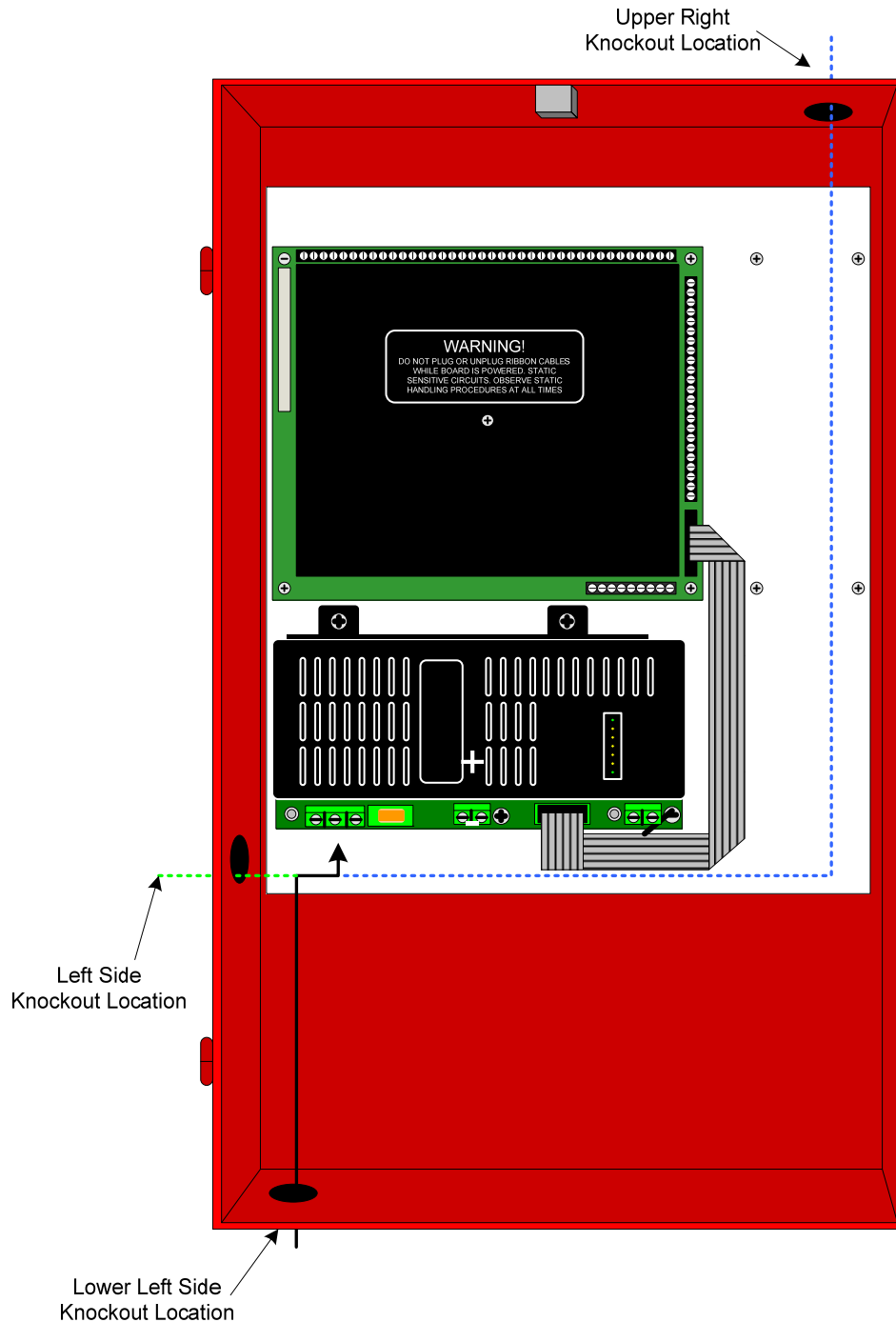

The preferred entry location for AC input power is via the left side knock-out (see green dotted line above). DO NOT route AC input power across the main control board (K6002), the ribbon cable interconnects, or directly across or adjacent to the low-voltage connections made on terminal strips X1 (top) or X2 (side).

## 2.6 Battery Calculations

### FireNET Battery Calculator Tool

The FireNET Battery Calculator Tool will help you determine the batteries needed for your installation. In order to use this tool you must know the number and type of devices that will be attached to your control panel, and the current requirements of any auxiliary devices being powered by the control panel.

The blue boxes are the standby and alarm subtotals; these are added together when the form is completed to determine the minimum battery size required

For "SLC Device Communication Current" and "5 Device Alarm LEDs", enter the standby and alarm current shown for each SLC that is in use.

How much **Standby Time** (in hours) is required for the installation?

Hours

How much **Alarm Time\*** (in minutes) is required for the installation?

Minutes

FireNET Panel Hardware	SLC 1	SLC 2	SLC 3	SLC 4	Panel Totals	Panel Standby Current	Total Standby Current	Panel Alarm Current	Total Alarm Current	
FN2127 2-Loop Panel	1				1	0.35000	0.35000	0.62000	0.62000	
FN4127-SLC Loop Expander	Enter standby and alarm current if FN4127-SLC is used					0.10000		0.10000		
FN4127-NIC Network Card	Enter standby and alarm current if FN4127-NIC is used					0.06000		0.06000		
FN-DAC Digital Alarm Communicator	Enter standby and alarm current if FN-DAC is used					0.02000		0.02000		
SLC Device Communication Current						0.00675		0.00675		
5 Device Alarm LEDs						0.00000	0.00000	0.04000		
							S1	A	A1	A

SLC Devices	SLC 1 Devices	SLC 2 Devices	SLC 3 Devices	SLC 4 Devices	Device Total	Device Standby Current	SLC Standby Current	Device Alarm Current	SLC Alarm Current
ALG-V Analog Photo Smoke						0.00039		0.00054	
ALK-V Analog Photo Smoke						0.00039		0.00080	
ALN-V Analog Photo Smoke						0.00045		0.00054	
ACA-V Analog Multi-Sensor						0.00045		0.00054	
ACC-V Analog Multi-Sensor						0.00045		0.00054	
AIE-EA Analog Ion Smoke						0.00035		0.00046	
ATG-EA Analog Heat Sensor						0.00035		0.00050	
ATJ-EA Analog Heat Sensor						0.00035		0.00050	
Quantity of SLC-Powered Alarm LEDs						0.00000	0.00000	0.00800	
ASB Analog Sounder Base						0.00011		0.00011	
DH98-A Analog Duct Detector						0.00039		0.00054	
DH98-AR Analog Duct Detector w/Relay						0.00039		0.00054	
DH-99-A Analog Duct Detector						0.00039		0.00054	
DH-99-AR Analog Duct Detector w/Relay						0.00039		0.00054	
FRCME-4, P Input Module						0.00055		0.00066	
FRCMA Class A Input Module						0.00063		0.00630	
FRCMA-I Class A Input Module + SCI						0.00063		0.00630	
FRCME-M Input Module						0.00034		0.00036	
DIMM Dual Input Monitor Module						0.00060		0.00072	
AMS Addressable Pull Station						0.00055		0.00066	
CZM Conventional Zone Module						0.00068		0.00072	
SOM Supervised Output Module						0.00015		0.00016	
SOM-A Class A Output Module						0.00042		0.00050	
SOM-AI Class A Output Module + SCI						0.00042		0.00050	
SOM-R Supervised Output Module						0.00015		0.00016	
R2M Dual Relay Module						0.00039		0.00040	
R2ML / R2MH Dual Relay Module						0.00035		0.00041	
R2ML-I / R2MH-I Dual Relay Module + SCI						0.00035		0.00041	
SCI Short Circuit Isolator						0.00027		0.00027	
SCI-B6 / SCI-B4 Short Circuit Isolator Base						0.00016		0.00016	
<b>Total</b>						S2	A	A2	A

Notification Appliance Circuits	NAC 1	NAC 2	NAC 3	NAC 4
NAC Appliance Current per Circuit				
Standby Aux Power from SLC above				
Alarm Aux Power from SLC above				
Standby Aux Power from page 2				
Alarm Aux Power from page 2				
<b>Total NAC standby current</b>				
<b>Total NAC alarm current</b>				

NAC  
STANDBY  
TOTAL

S3

A

NAC  
ALARM  
TOTAL

A3

A

Continue calculation on Page 2.

Revision 2.04m



## 2.7 Electrical Ratings

**Table 2.7.1 (X1) Top Terminal Strip Electrical Ratings for Main Control Unit**

Terminal # and Label		Description	Rating		
			Voltage	Current	
1	- OUT	SLC 1 Signaling Line Circuit. Out terminals used for Class B or A wiring.	32VDC	400mA	
2	+ OUT		32VDC	400mA	
3	- IN		Signaling Line Circuit. In terminals used for Return Loop for Class A wiring.	32VDC	400mA
4	+ IN			32VDC	400mA
5	- OUT	SLC 2 Signaling Line Circuit. Out terminals used for Class B or A wiring.	32VDC	400mA	
6	+ OUT		32VDC	400mA	
7	- IN		Signaling Line Circuit. In terminals used for Return Loop for Class A wiring.	32VDC	400mA
8	+ IN			32VDC	400mA
9	- OUT	SLC 3 Signaling Line Circuit. Out terminals used for Class B or A wiring.	32VDC	400mA	
10	+ OUT		32VDC	400mA	
11	- IN		Signaling Line Circuit. In terminals used for Return Loop for Class A wiring.	32VDC	400mA
12	+ IN			32VDC	400mA
13	- OUT	SLC 4 Signaling Line Circuit. Out terminals used for Class B or A wiring.	32VDC	400mA	
14	+ OUT		32VDC	400mA	
15	- IN		Signaling Line Circuit. In terminals used for Return Loop for Class A wiring.	32VDC	400mA
16	+ IN			32VDC	400mA
17	NC	Fire 1 Fire condition relay contacts #1.	30VDC	1 A	
18	C		30VDC	1 A	
19	NO		30VDC	1 A	
20	NC	Trouble Trouble condition relay contacts.	30VDC	1 A	
21	C		30VDC	1 A	
22	NO		30VDC	1 A	
23	NC	Fire 2 Fire condition relay contacts #2.	30VDC	1 A	
24	C		30VDC	1 A	
25	NO		30VDC	1 A	
26	NC	Supervisory Supervisory relay contact.	30VDC	1 A	
27	C		30VDC	1 A	
28	NO		30VDC	1 A	
29	NC	Auxiliary Programmable auxiliary relay contacts.	30VDC	1 A	
30	C		30VDC	1 A	
31	NO		30VDC	1 A	
32	+	NAC 1 Notification Appliance Circuit #1. 10K EOLR Required.	24VDC	2.5 A*	
33	-		24VDC	2.5 A*	
34	+	NAC 2 Notification Appliance Circuit #2. 10K EOLR Required.	24VDC	2.5 A*	
35	-		24VDC	2.5 A*	
36	+	NAC 3 Notification Appliance Circuit #3. 10K EOLR Required.	24VDC	2.5 A*	
37	-		24VDC	2.5 A*	
38	+	NAC 4 Notification Appliance Circuit #4. 10K EOLR Required.	24VDC	2.5 A*	
39	-		24VDC	2.5 A*	

\*Note: See Section 2.8 for additional details regarding NAC circuit ratings

**Table 2.7.2 (X2) Side Terminal Strip Electrical Ratings for Main Control Unit**

Terminal # and Label		Description	Rating		
			Voltage	Current	
1	+	Fire Routing	Supervised fire signaling output	24VDC	500mA
2	-			24VDC	500mA
3	+	Trouble Routing	Supervised trouble signaling output	24VDC	500mA
4	-			24VDC	500mA
5	+	Programmable Output	Supervised programmable output	24VDC	500mA
6	-			24VDC	500mA
7	TBL	Trouble Input	Remote control input	0V	30mA
8	RES	Reset Input	Remote control input	0V	30mA
9	INT	Intermittent Input	Remote control input	0V	30mA
10	CNT	Continuous Input	Remote control input	0V	30mA
11	SIL	Silence/Ack Input	Remote control input	0V	30mA
12	0V	DC Ground	Signal for activating remote inputs	0V	500mA
13	PR1	Programmable Input 1	Auxiliary input	0V	30mA
14	PR2	Programmable Input 2	Auxiliary input	0V	30mA
15	PR3	Programmable Input 3	Auxiliary input	0V	30mA
16	+	COMMS	RS485 to I/O boards	12VDC	100mA
17	-		RS485 to I/O boards	12VDC	100mA
18	+	AUX 24V	Auxiliary 24V supply	24VDC	500mA
19	-		Auxiliary 24V supply	24VDC	500mA
20	+	NETWORK IN	RS485 to other panels	12VDC	100mA
21	-		RS485 to other panels	12VDC	100mA
22	+	NETWORK OUT	RS485 to other panels	12VDC	100mA
23	-		RS485 to other panels	12VDC	100mA

**Table 2.7.3 Terminal Strip Electrical ratings for the Power Supply Module**

Connector	Terminal	Description	Rating	
			Voltage	Current
TB6	G	Earth Ground	N/A	N/A
	N	AC Neutral	120 VAC, 50/60Hz	2.1A
			240 VAC, 50/60Hz	1.1A
	L	AC Line	120 VAC, 50/60Hz	2.1A
240 VAC, 50/60Hz			1.1A	
TB4	+24VDC	+ DC Output	+24 VDC	0 - 4 Amps
	DC RTN	- DC Output	DC Common	0 - 4 Amps
TB3		+ Battery	+24 VDC	5A
		- Battery	DC Common	5A

**NOTE:** Earth ground fault detection impedance is approximately 15K ohms between earth ground and the FireNET internal floating DC supply.



## 2.8 Specifications

---

Primary AC:	120VAC @ 2.1 amps 50/60hz (or) 240VAC @ 1.1 amp 50/60hz
Output DC:	24VDC @ 4 amps
Power Supply:	5.25 amp integrated (4 amp + 1.25 amp for battery charging circuit)
Max Charger Current:	1.5 amps
Dimensions:	14.5"W x 24" H x 5"D
Weight:	31 lbs (without batteries)
Color:	Red (optional charcoal)
Material:	ABS/steel enclosure
Display:	8 line x 40 character LCD (320 characters total)
Network:	Dual RS485 ports (64 panels max.)
Zones:	500 network wide software zones per system (Output zones allocated to zones 1 to 253 only for SOM 2.0 and earlier)
SLC loops:	2 or 4 (class A or B)
Devices per Loop:	127 sensors & modules, plus 127 analog sounder bases, 254 total
Addresses per Panel	(800 addresses + sub-addresses max per panel)
NAC Outputs:	(4) 2.5 amp@24VDC (class B)*
Relay Outputs:	(5) Form C contact 1amp@30VDC
Voltage Outputs:	(3) 500mA@24VDC
Aux. Power:	500mA@24VDC
Aux. Inputs:	(8) digital pull downs
PC Port:	RS232
Printer Port:	RS232

**\*NOTE:** FireNET panels dated 1/24/05 or later with s/n 411-00412 or later have NAC circuits rated at 2.5AMPS each. All FireNET panels dated earlier than 1/24/05 with s/n prior to 411-00412 have NAC circuits rated at 1.6AMPS each.

**\*NOTE:** NAC circuit ratings shown above have been evaluated under special applications. Regulated rating = .25 amps per circuit

## Section 3 - Power Supply and Main Control Unit Connections

### 3.1 AC Power Connection

---

The AC power connection terminals are located in the lower left hand corner of the power supply module. (See Figure 3.3) Observe the wiring polarity and connect as shown. Local electrical codes may require that a licensed electrician make these connections.

NFPA 72 requires that the AC connection be made from a dedicated branch circuit that is mechanically protected. The circuit must be marked in red and identified as a "FIRE ALARM CIRCUIT". The location of the circuit and its disconnecting means shall be permanently noted at the fire alarm control panel. The circuit breaker must be rated at 20 amps maximum.

**Fuse Replacement:** To replace the power supply fuse F2, power down the fire system by removing the AC power first, then disconnect the backup batteries to the fire alarm control panel. Remove the blown fuse and replace with a 3A 250VAC, slow blow, 5X20mm fuse. When the fuse replacement is completed, restore AC power to the control panel and connect the back up batteries observing polarity of connections.

### 3.2 Battery Connection

---

The FireNET 2127/4127 fire alarm control panel can charge up to 50AH batteries. Up to 17 AH will fit in the control panel enclosure, as well as larger sizes that have the same size footprint as 17AH batteries. Batteries larger than 17AH may be mounted remotely in the FN-ACC accessory cabinet. Use the current draw and battery calculation worksheet in section 2.6 to determine the appropriate size battery to use.

Two battery leads come pre-connected to the power supply module. Connect two 12-volt batteries in series to the battery leads as shown in Figure 3.3. Both batteries must be of the same AH rating. Do not try to parallel multiple batteries together to obtain a higher AH rating. Use only UL Recognized Sealed Lead Acid Batteries.

**Fuse Replacement:** To replace the in-line battery fuse, remove the battery lead (RED) from the positive battery terminal and twist the bayonet fuse holder to open. Remove the blown fuse and replace with a "Bussman AGC-10" (10A) type fuse or equivalent. Reassemble bayonet fuse holder and attach the battery lead to the + terminal of the battery.

NOTE: The standby batteries cannot power the system until the main 120VAC power has been established. Once the system has been initially powered from them 120VAC source the batteries will operate the system in the event of a power failure.

### 3.3 Auxiliary Power Connection

24 VDC auxiliary power is available on the main control unit X2 terminal strip from terminals 18 and 19. (See Figure 3.4) This auxiliary power is intended to run expansion boards or other low current auxiliary devices.

The total output from the Auxiliary Power terminals must not exceed .500 amps.

Any devices powered from the auxiliary power terminals should be entered into Table 2.6 and taken into consideration for standby battery size.

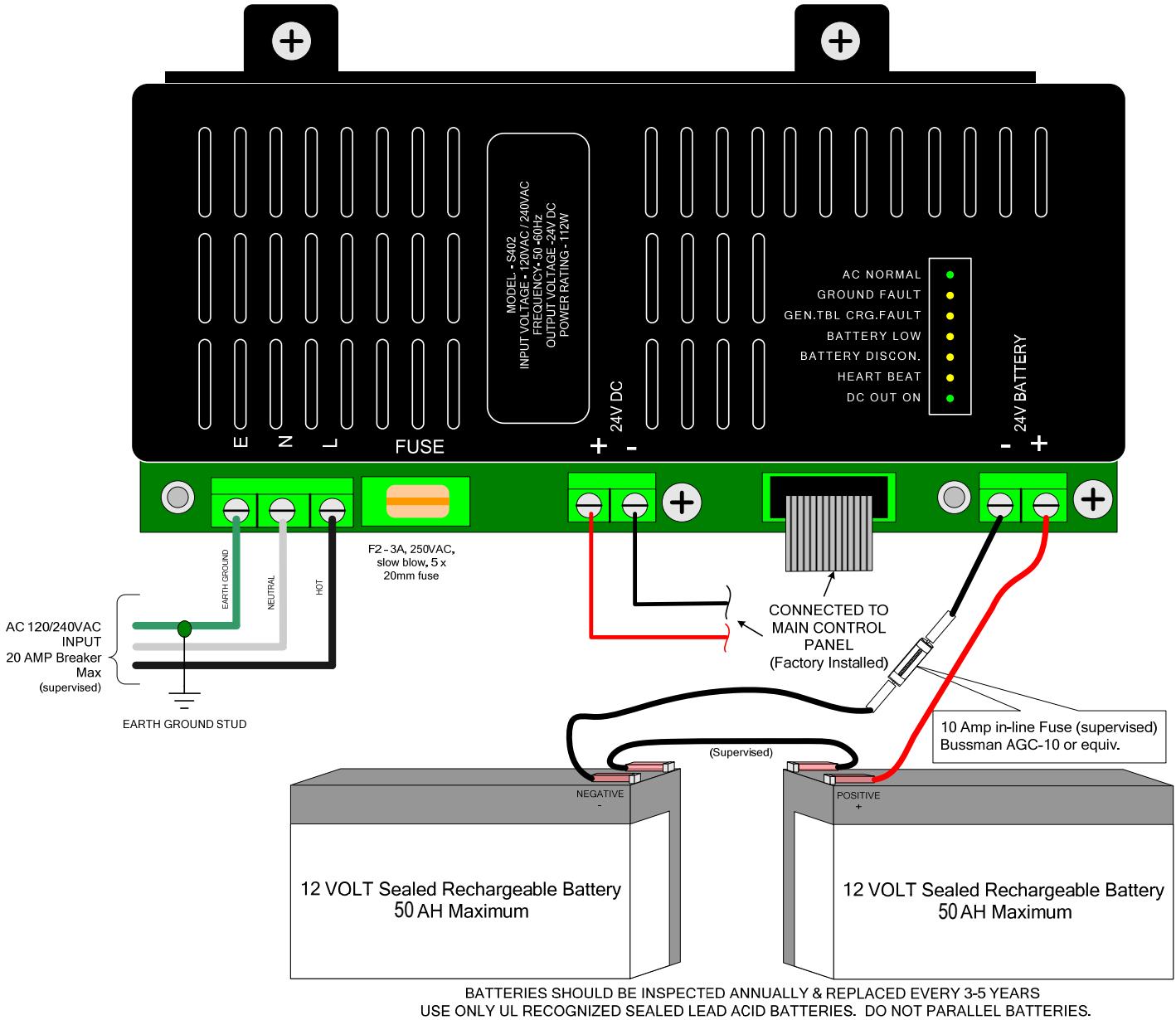
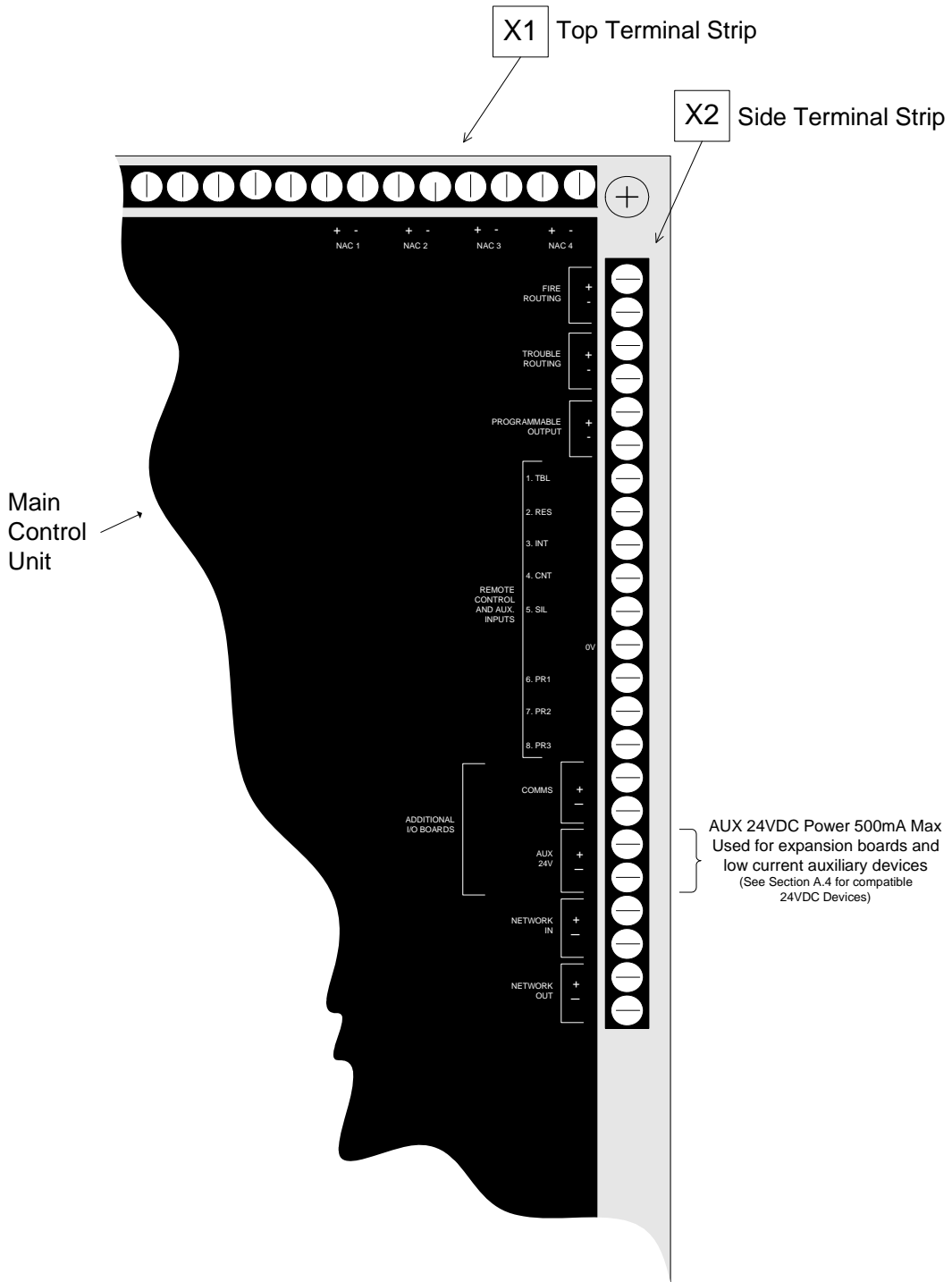

Figure 3.3 5.25-Amp Power Supply Detail



**Figure 3.4 Auxiliary Power Connection Detail**

### 3.4 Notification Appliance Circuit Connection

- NAC output rated @ 2.5 Amp each.
- See Appendix A.3 for compatible NAC Devices.
- See Section 8 of this manual for programming.

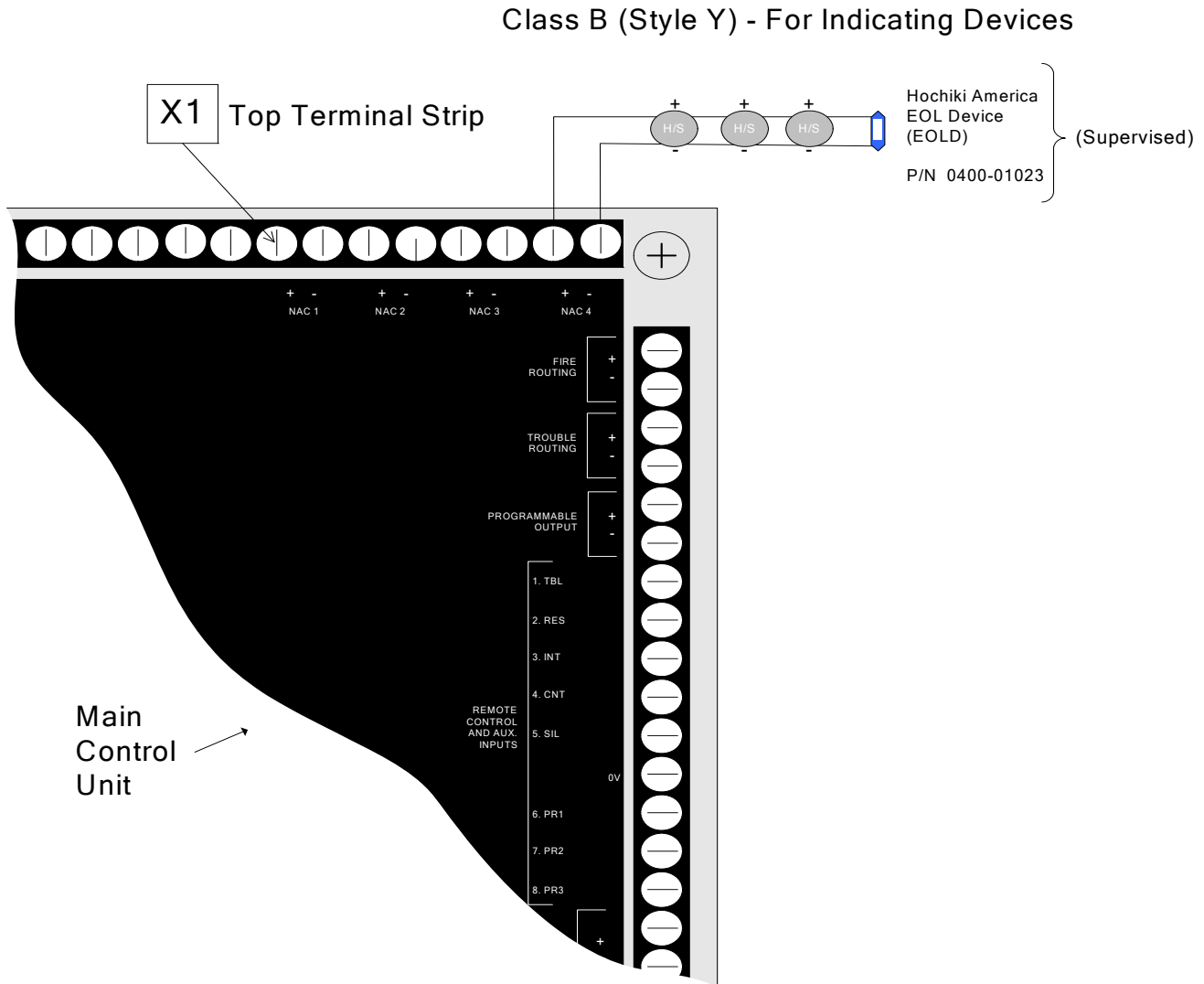

**Figure 3.5 Notification Appliance Circuit Connection Detail**

## 3.5 Voltage Routing and Relay Output Connection

### 3.5.1 Voltage Routing Outputs

- Outputs are fully programmable.
- Outputs are rated @ 500mA Max.
- Outputs are polarity reversing.
- See Appendix A.4 for compatible devices.
- See Section 8 of this manual for programming.

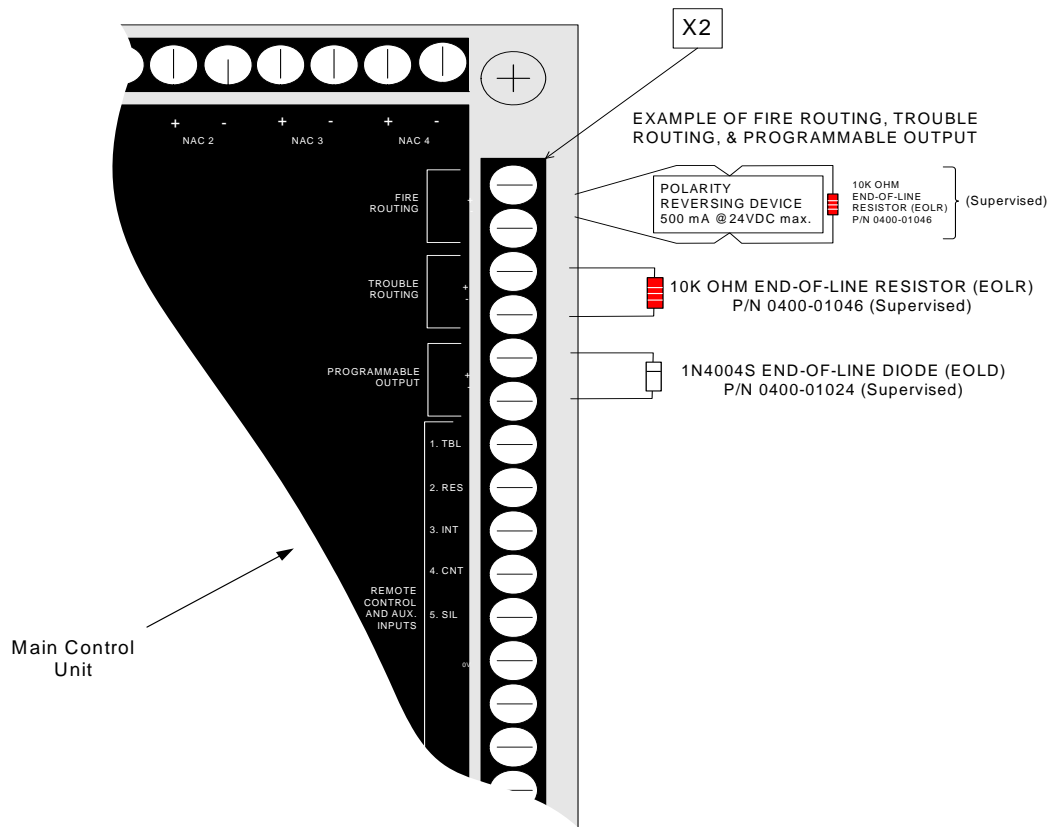

Figure 3.6 Voltage Routing Outputs Detail

### 3.5.2 Relay Outputs

- Relays are fully programmable except for the supervisory relay.
- The auxiliary relay defaults to reset function that can be used to reset conventional devices requiring power reset. This inherent function is negated when the auxiliary is assigned a function.
- Relays are dry form “C” contacts.
- Fire 2 Relay can optionally be programmed as an AC Fail relay with a delay value.
- See section 8 of this manual for programming.

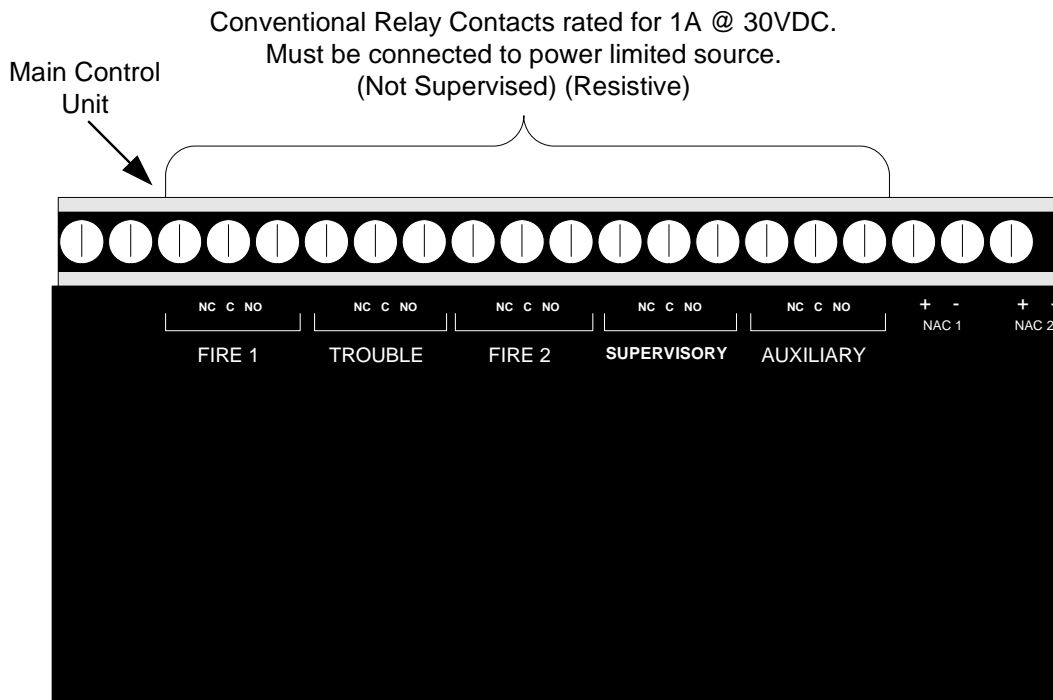
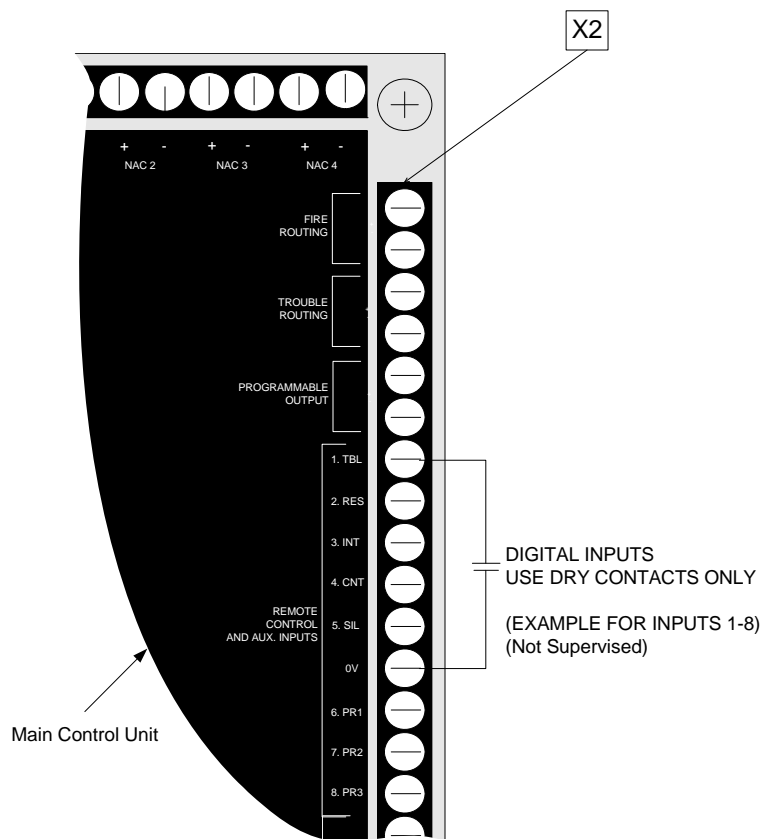

Figure 3.7 Relay Outputs Detail

### 3.6 Digital Input Connection

- Digital Inputs are fully programmable.
- Digital Inputs are for secondary use only.
- Digital Inputs are pull-down type.
- Digital Inputs are not supervised.
- Digital Inputs are not intended for use with primary initiating devices for fire conditions.
- These inputs are activated via N.O. dry contact or switch by connecting terminal 12 on X2 to the input.
- See Section 8 of this manual for programming.



**Figure 3.8 Remote Control Input Connection Detail**



### ***3.7 Using a Printer***

---

The FireNET panel will support a local serial printer. The printer connects to the J10 RS-232 port (labeled Printer) on the inside of the front door. J10 is located in the bottom left-hand corner of the circuit board. The printer cable must be no longer than 20 feet in length. The printer can be used for real-time logging of events. It can also be used to print the panel's configuration (see section 8.2.4) or to print the panel's history log (see section 10.2.2).

#### Serial Printer Properties:

- 19.2K Baud
- 8 Bits
- No Parity
- 1-Stop Bit

### ***3.8 Computer / Programming Port Connections***

Panel may be connected to a remote computer with EMS Graphix capability and used as a supplemental remote annunciator. The connection between the Computer Programming port must be within 20 FT in the same room and in conduit. A DACT Interface module cannot be used on a Panel / Node which has this connection.

A DACT Interface module may be used on another node within a network topology.

## Section 4 – Expander Board Installation

### ***4.1 Compatible Expander Boards***

---

The following Hochiki America Corp. expander boards are listed as compatible with the FireNET 2127/4127 analog addressable fire alarm system.

#### **Expanders**

- FN-4127-SLC - Dual SLC Loop Expander (Local FACP Expander)
- FN-4127-IO – 16 Channel Input / Output Board (RS-485 Bus Device)
- FN-LCD-S Serial LCD Annunciator (RS-485 Bus Device)

This section covers the installation of the devices listed above. The FireNET panel must be properly programmed after the installation of expander boards. Please refer to Section 8 of this manual for more information on programming the functionality of expander boards.

## ***4.2 General Installation of RS-485 Bus Devices***

---

### **4.2.1 Wiring Distance and Mounting Locations**

RS485 bus devices can be mounted either in the main control panel on the standoffs provided to the right of the control unit, or in an accessory cabinet (FN-ACC). When mounting remotely in an accessory cabinet the distance from the panel to the RS485 bus device must not exceed 4000 feet. A suitable communications cable for RS485 applications must be used for the RS485 bus devices.

Specific wiring connections for each device are included later in this section. For specific wiring distance, connections, and mounting of the FN-LCD-S serial LCD Annunciator, see Section 4.7.

## 4.2.2 Addressing

Up to 32 RS485 bus devices can be added to the system. Each RS485 bus device must be set to a unique address 1-32.

The address for each RS485 bus device is set using a position DIP-switch in binary fashion. Switches 1-6 represent the values 1, 2, 4, 8, 16, and 32 respectively. To set the address, move only the switches whose values when added equal the address value you wish to set, to the "ON" position. For example moving switches 1 and 3 (whose values are 1 and 4 respectively) to the "ON" position sets the address of 5 into the RS485 bus device. See the other examples below:

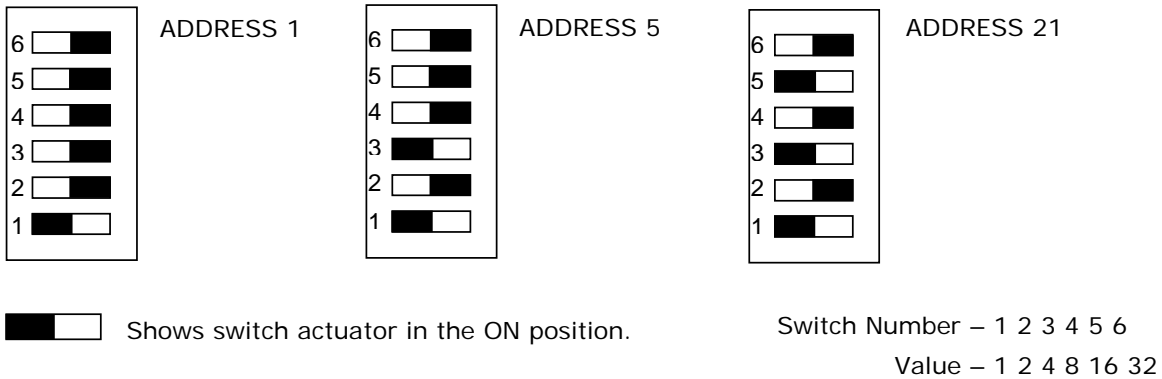

Addresses must be set with no power applied to the system.

## 4.2.3 Terminating

The last board connected to the RS485 bus must have a terminating jumper installed at position J3 as shown in figure 4.2.3.1

Even if only 1 RS485 bus device is connected to the panel this jumper must be installed.

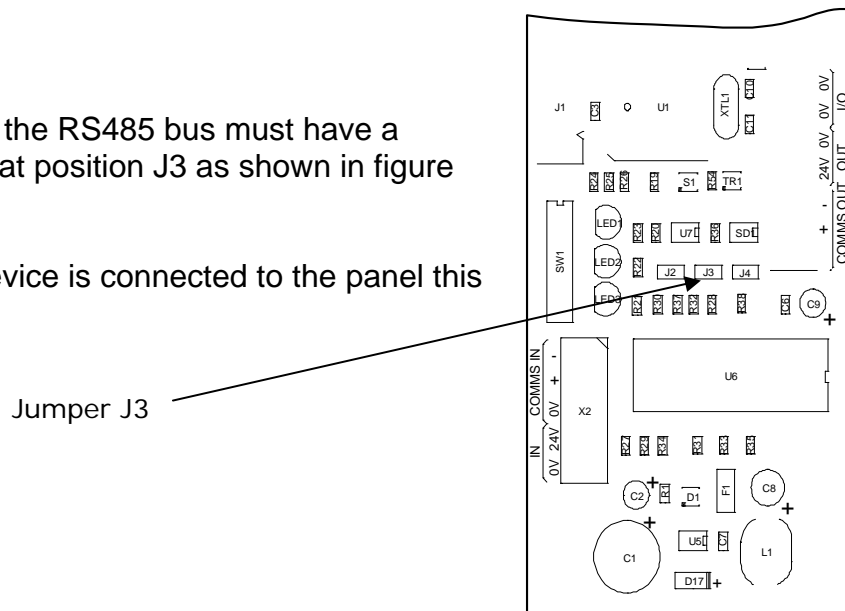

**Figure 4.2.3.1**

## 4.2.4 Power Connections

All RS485 bus devices require 24 VDC to operate. The AUX 24V terminals of the FN-2127/4127 can supply this voltage (500 milliamps maximum) or you may use an external power supply that provides 24 VDC output.

Connections are provided on each RS485 bus device for both incoming and outgoing power.

## 4.2.5 COMMS Connection

In addition to power, each RS485 bus device requires a pair of conductors for data communication. This wiring is connected to the COMMS + and - terminals on the FN-2127/4127 control panel or can be connected to the COMMS OUT + and - terminals of another RS485 bus device.

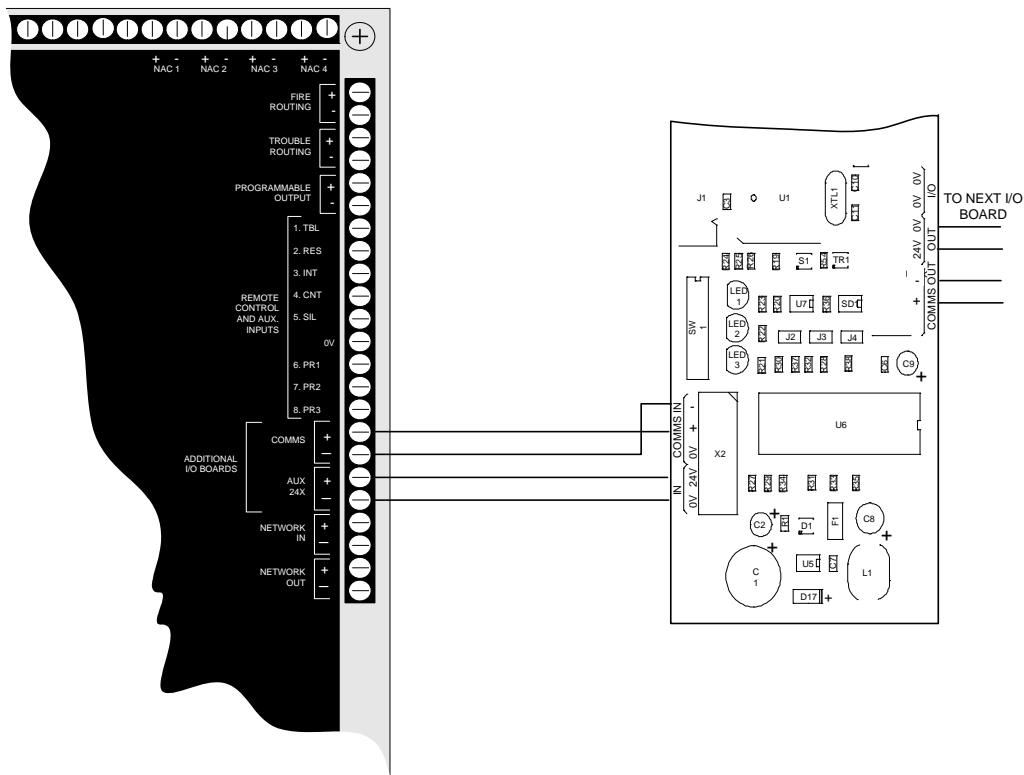

### 4.3 FN-4127-IO - Input / Output Board

In addition to the basic 508 points that the FireNET 2127/4127 can accommodate on the SLC loops additional input and output points can be added by using FN-4127-IO Input / Output boards on the RS485 bus.

The FN-4127-IO has 16 channels. Each channel can be individually configured as either an input or an output. Up to 32 FN-4127-IO boards can be connected to the system via the RS485 bus giving the system an additional 512 inputs/outputs.

#### 4.3.1 Configuring Inputs

Inputs to the FN-4127-IO are optically isolated and connected to the board by installing a normally open contact with a resistance no greater than 500 ohms to input and a terminal marked 0V. The current switched by the contact will be a maximum of 3 milliamps.

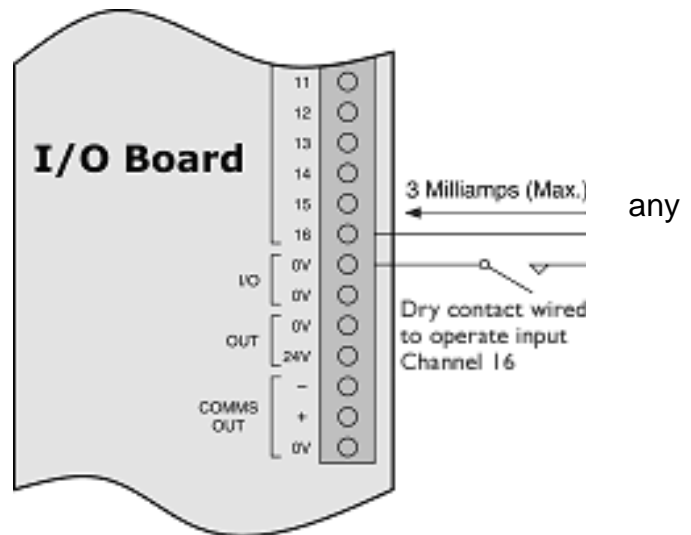

**NOTE:** Inputs on the I/O board are not supervised. These inputs are not for primary initiating or detection of fire or life safety conditions. These inputs are for programmable for secondary use only, and not used for signaling Fire, Supervisory, or Trouble conditions. All primary initiating or detection inputs must be connected to applicable SLC devices listed for fire. See Section 5 of this manual for SLC devices.

### 4.3.2 Configuring Outputs

When configured as outputs, the I/O board channels supply a negative voltage (with respect to the I/O board 24V power supply) via a transistor.

Because transistor elements can be damaged by excessive current drain, great care should be taken when connecting to outputs. Particular care should be taken to ensure that suppression diodes on relay coils are correctly polarized. Wrongly connected diodes will damage the outputs. Diodes should be connected with the band to the positive 24V.

Individual channels can supply current up to 100 milliamps but this must be limited to 500 milliamps for each bank of eight (500 milliamps for 1-8 and 500 milliamps for 9-16). The power supply to the I/O board should also be considered to ensure that its rating is not exceeded if multiple channels are switched on. Overall current draw for the I/O board is 1010mA max.

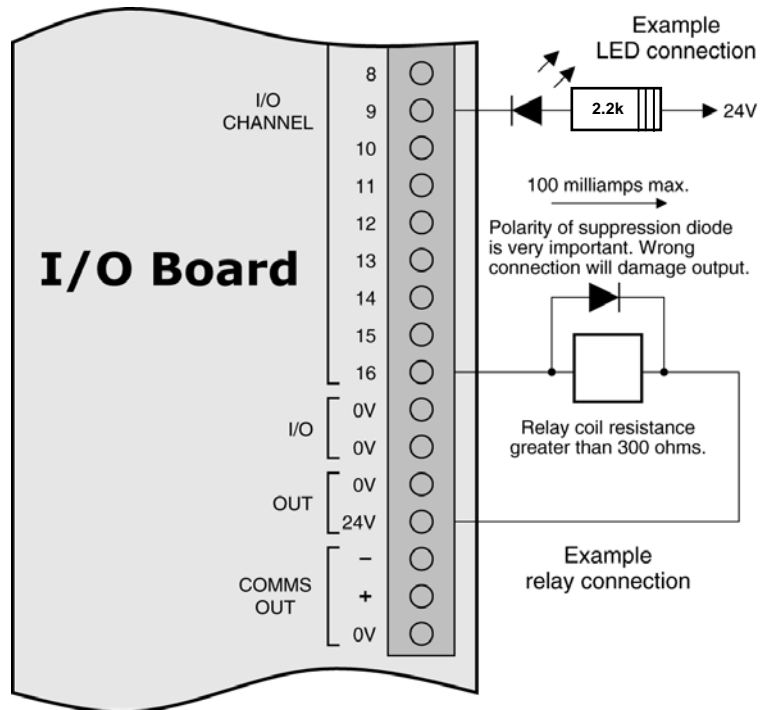

**NOTE:** Outputs on the I/O board are not supervised. These outputs are not for primary notification of fire conditions (i.e. not for use as NAC circuits). These outputs are for secondary use only. All primary notification output devices must be connected to applicable NAC circuits on the FireNET panel. See Section 3.4, Appendix A, and B for details on NAC circuits and compatible NAC devices.

When powering the I/O board from the FireNET Aux 24VDC power (limited to 500ma), the following maximum wiring distances apply at the gauges noted:

<u>Wire</u>	<u>Distance</u>
18AWG	875ft
16AWG	1400ft
14AWG	2300ft

When powering the I/O board from a separate Aux 24VDC UL Fire listed supply the maximum voltage drop cannot exceed 4VDC.

### 4.3.3 LED Indicators

LED indicators on the I/O board give some simple diagnostic information and show that the boards are communicating with the control panel. The red LED (LED1) is on during receipt of a message from the control panel and will turn off if the I/O board feels the communication is normal.

- **If the LED is flickering more or less continuously** - the board is operating normally.
- **If this LED is not lit** - the board is not receiving data from the control panel and the comms connection should be checked.
- **If this LED is permanently lit** - then it is likely that data is being received but that it is being corrupted. In this case the quality of the comms connection should be checked for interference from mains or other noise generating sources.

The yellow LED (LED2) will flicker briefly every few seconds when the I/O board responds to the main panel. If this LED does not flicker then it is not responding to the control panel and the comms connection should be checked.

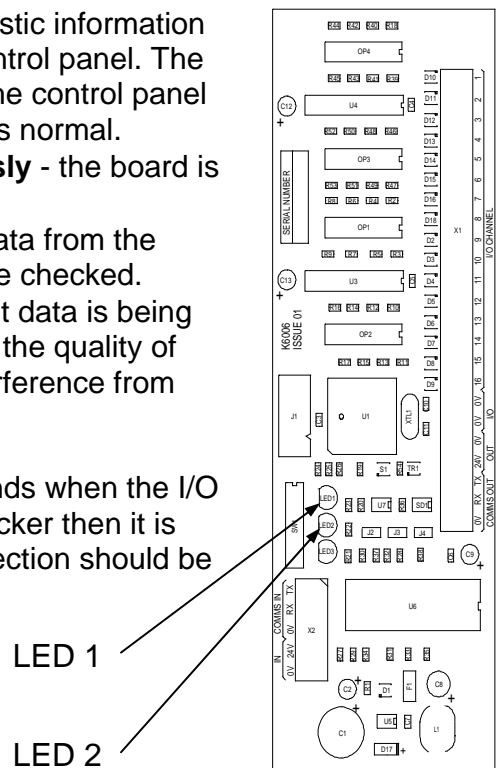

### 4.4 Reserved for Future Use

---

### 4.5 Reserved for Future Use

---



## 4.6 FN-4127-SLC – Dual SLC Loop Expander

---

The FN-2127 FireNET control panel is provided with two SLC Loops; however an additional two SLC Loops may be added at the factory or a later date if required through the use of a FN-4127-SLC expander board.

The main control unit has terminations for connecting all four SLC loops, but on the basic 2-loop control panels not using an SLC loop expander there is no circuitry for SLC loops 3 & 4. The FN-4127-SLC dual loop expander board adds circuitry for loops 3 & 4.

### 4.6.1 Installation of the FN-4127-SLC

1. To install the additional SLC Loops, the control panel must have its 120V AC line and battery power removed.
2. The metal cover on the terminal board should be removed by loosening the single screw in the center of the cover.
3. The circuit board containing the additional loop circuits is supplied in a static dissipative bag and should remain in this bag until it is to be installed.

**NOTE:** As with all electronic components, this circuit board is very sensitive and can be easily damaged by electrostatic discharge.

4. The loop board mounts on the left hand side of the terminal board and fits upside down compared with the existing circuit. The additional 2-loop circuit board is supplied with 2 ribbon cables of different sizes and the board should be oriented so that the ribbon cables match the connectors.
5. Install the four mounting standoffs to the main board, then attach the additional 2-loop board using the M3 screws and fiber washers.
6. After checking that the new circuit board is properly installed and making good contact with its connectors, the metal cover should be replaced. Connect the SLC loop wiring, then re-apply power to the control panel.
7. Unused detection circuits must have the "loop + out" to "loop + in" and "loop - out" to "loop - in" terminals wired together to prevent open circuit troubles from being reported. Class B SLC circuits also require the 0 ohm jumpers to be installed – please see Section 5.3.1.

Once the detection circuits have been connected, the devices for the new detection circuits can be automatically detected using the auto learn feature from the menu on the control panel (see Section 8 of this manual).

## 4.7 FN-LCD-S Serial Liquid Crystal Display Annunciator

The FN-LCD-S Serial LCD Annunciator duplicates the indications of the FN-2127/4127 fire alarm control panels. The FN-LCD-S connects to the control panel via RS485 serial buss that is designated “Additional I/O boards – COMMS” on the K6002 board. Up to 15 FN-LCD-S units can be connected via RS485 serial port to a single FireNET panel.

### 4.7.1 Installation of the FN-LCD-S

Refer to section 2.2 of this manual for environmental installation specifications. The FN-LCD-S should be mounted so that it is accessible to service personnel and located in an area in compliance with local regulations.

The FN-LCD-S may be surface or flush mounted. Do not mount directly to a concrete wall. Use a suitable standoff material such as plywood to keep condensation away from the annunciator.

For operations and programming, refer to Sections 7 and 8 of this manual. The FN-LCD-S operates in the same manner as the main panel operator interface and controls.

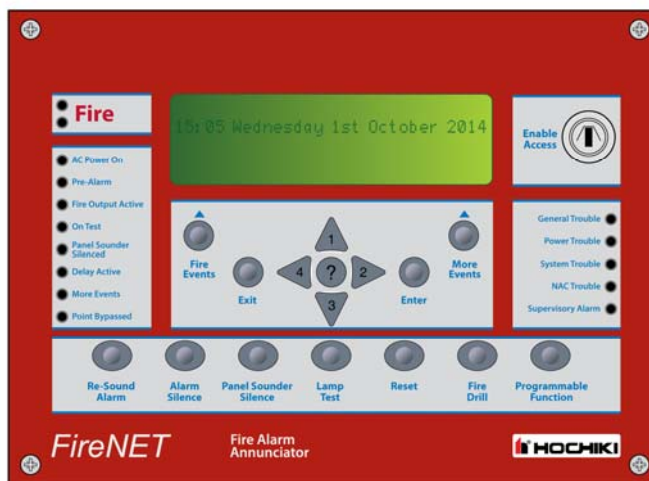

Figure 4.7.2 FN-LCD-S Serial LCD Annunciator

When powering the FN-LCD-S from the FireNET Aux 24VDC power (limited to 500mA) or an external UL864/1481 Listed AUX 24VDC supply, the following maximum wiring distances apply to the power cables at the gauges noted:

Wire Run	Wire AWG			
	20	18	16	14
1000 ft.	6	9	15	15
2000 ft.	3	4	7	12
3000 ft.	2	3	5	8
4000 ft.	1	2	3	6

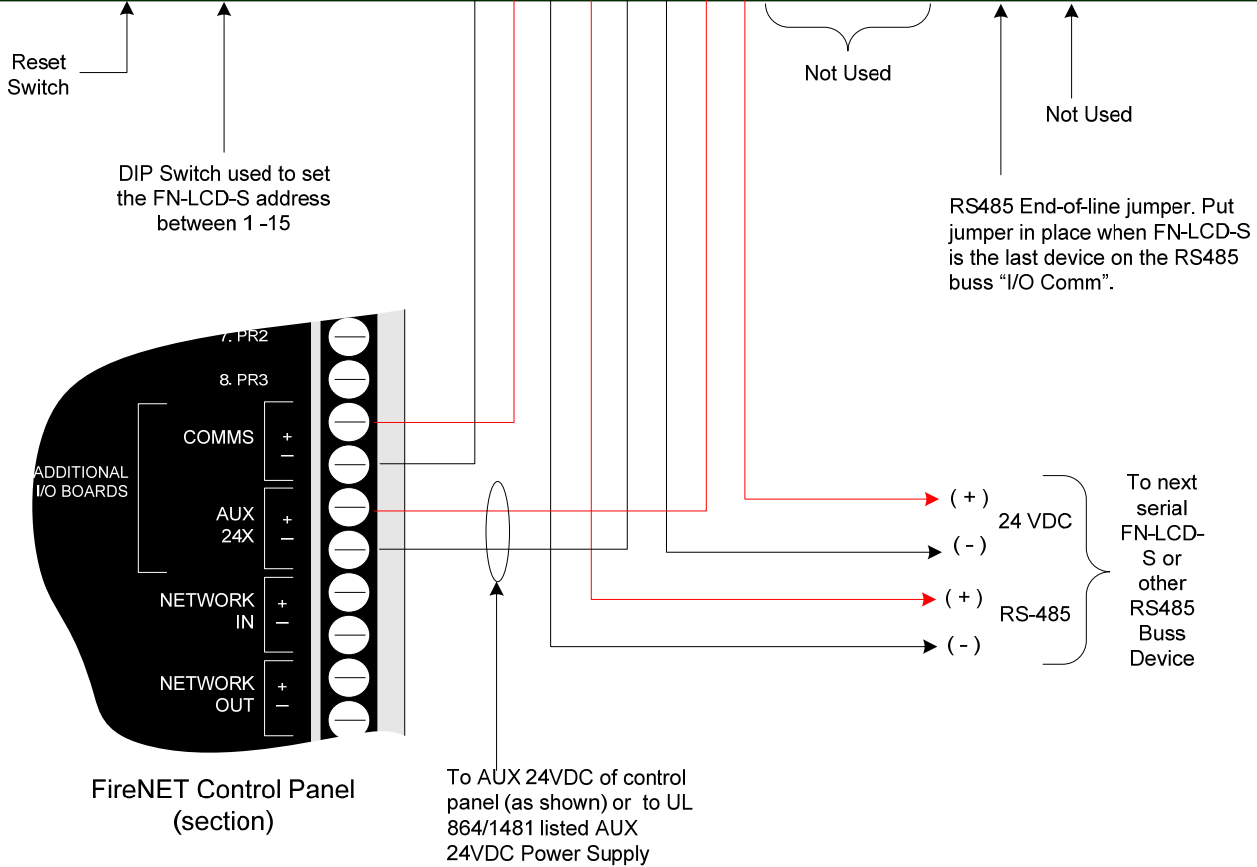
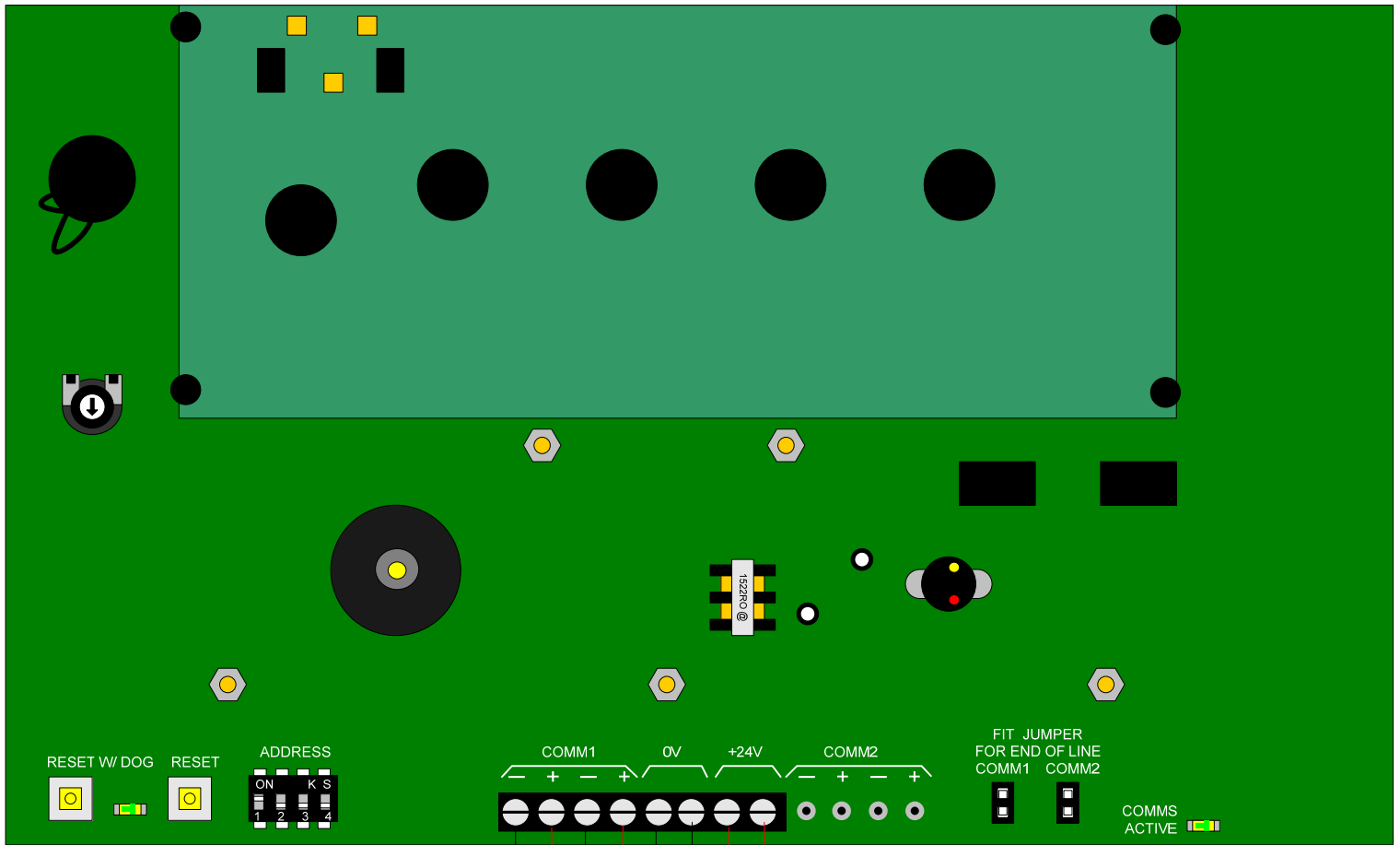

Figure 4.7.3 FN-LCD-S Wiring Detail

**NOTE:** When connecting I/O boards to the FN-LCD-S via the COMMS terminals shown above, the I/O boards must be powered by a UL864/1481 listed local Auxiliary 24VDC power supply, or the Aux 24VDC output of the FN-LCD-S within the limits outlined below.

DO NOT connect the I/O board power input to the Aux 24VDC output terminals of the FN-LCD-S unless the sum current load of the I/O board is within the 500mA max 24VDC output rating of the FN-LCD-S and within the 500ma max 24VDC output rating of the FN-2127/4127 control panel that provides power to the FN-LCD-S. Failure to make this consideration may result in overloading the FN-LCD-S and/or the control panel Aux 24VDC output (500ma max. each).

The current limits during both standby and in alarm shall not exceed the 500mA rating of the FN-2127/4127 Panel Aux 24VDC output or FN-LCD-S.

The FN-LCD-S current draw is rated as follows:

Standby: 20mA @ 24VDC

Alarm: 110mA @ 24VDC

Available colors are RED and CHARCOAL as identified below:

FN-LCD-S-R = RED

FN-LCD-S-G = Gray

## Section 5 – SLC Device Installation

### 5.1 Compatible SLC Devices

---

The following Hochiki America Corp. SLC devices are listed as compatible with the FireNET 2127/4127 analog addressable fire alarm system.

#### **Detectors (Sensors)**

- ALK-V / ALK-V2 Analog Photoelectric Smoke Detector
- ALG-V Analog Photoelectric Smoke Detector
- ALN-V Analog Photoelectric Smoke Detector
- AIE-EA Analog Ionization Smoke Detector
- ATJ-EA Analog Heat Detector
- ATG-EA Analog Heat Detector
- ACA-V Analog Photoelectric and Heat Multi Detector
- ACC-V Analog Photoelectric and Heat Multi Detector
- DH98-A Analog Duct Smoke Detector, no Relay
- DH98-AR Analog Duct Smoke Detector with Relay
- DH99-A Analog Duct Smoke Detector, no Relay
- DH99-AR Analog Duct Smoke Detector with Relay

Smoke sensors will undergo automatic sensitivity testing and verification every 24 hours.

#### **Modules**

- DCP FRCME-4 Addressable Input Module
- DCP FRCME-S, FRCME-M Mini Addressable Input Module (with Terminal Blocks)
- DCP FRCMA Class A Addressable Input Module
- DCP FRCMA-I Class A Addressable Input Module (with SCI)
- DCP R2M, R2ML, R2MH Addressable Dual Relay Module
- DCP R2ML-I, R2MH-I Addressable Dual Relay Module (with SCI)

- DCP SOM Addressable Supervised Output module
- DCP SOM-A Addressable Class A Supervised Output Module
- DCP SOM-AI Addressable Class A Supervised Output Module (with SCI)
- DCP SCI Short Circuit Isolator
- DCP DIMM Dual Input Monitor Module
- CZM Conventional Zone Module
- ASB Analog Sounder Base
- DCP AMS Addressable Manual Pull-Station
- SOM-R Addressable Supervised Output Module (Preaction Sprinkler Systems)
- SCI-B6 Short Circuit Isolator Base 6”
- SCI-B4 Short Circuit isolator Base 4”

**NOTE:** The “DCP” prefix listed above on several devices indicates the device’s formal model name as specified by Underwriters Laboratories within each device’s individual listing. The “DCP” prefix will be dropped throughout the body of this manual and the shortened model name will be used. Please take note of this when referencing these devices within this manual.

## 5.2 Number of Devices

---

The FireNET 2127 comes with 2 SLC loops built-in to the panel. Each loop can support up to 127 analog addressable detectors and modules as well as 127 analog sounder bases for a total of 254 possible per loop. By adding the FN-4127-SLC expander card, 2 additional SLC loops can be added to the panel for a total of 4 loops.

Addresses 1 – 127 are reserved for any combination of detectors and modules. Addresses 128 – 254 are reserved for analog sounder bases. Detectors and modules cannot be addressed to the upper address 128 - 254. Each device on the SLC loop must have a unique address. Refer to section 5.4 for instructions on programming the address into each analog addressable device.

## 5.3 SLC Loop Wiring

---

The FireNET 2127/4127 uses the patented Hochiki DCP Digital Communication Protocol to communicate with each of the analog addressable devices located on the SLC loops. This extremely fast and reliable protocol allows the use of standard non-twisted, non-shielded wiring for the SLC loops.

The SLC loop wiring may be any solid or stranded cabling that meets the requirements for power limited fire protective signaling circuits listed in NFPA 70 (National Electrical Code) Article 760. The wiring resistance on the SLC loop must be less than 50 ohms. Loop capacitance must be less than 1 $\mu$ F. Loop inductance must be less than 1mH.

The SLC loop terminals are located on the upper left hand corner of the main control board. See Figure 5.3.

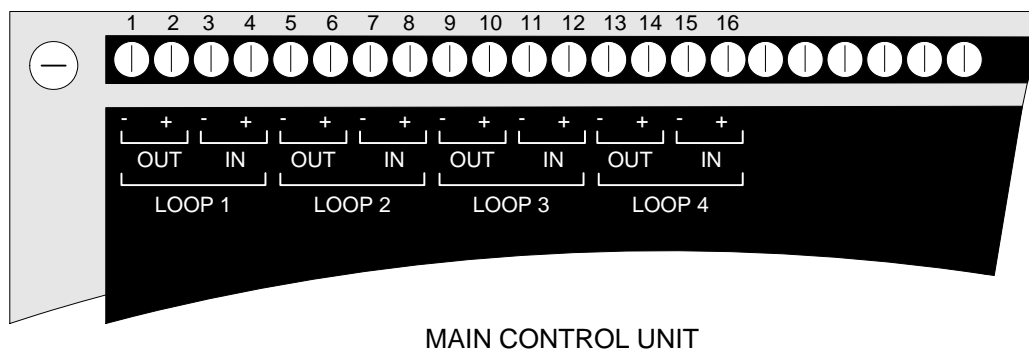

**Figure 5.3 SLC Loop Terminals**

### 5.3.1 Class B SLC Loop Wiring Distance

Refer to Figure 5.3.1 to determine the maximum length of wire that may be used on a Class B signaling line circuit (SLC). The total wire length of all branches (T-taps) on the SLC loop must not exceed 10,000 feet\* (per loop) using #14 AWG (see Figure 5.3.2). When using a Class B SLC wiring configuration, be sure that the 0 ohm jumpers supplied with the panel are properly installed between -OUT to -IN and +OUT to +IN (part #S2026).

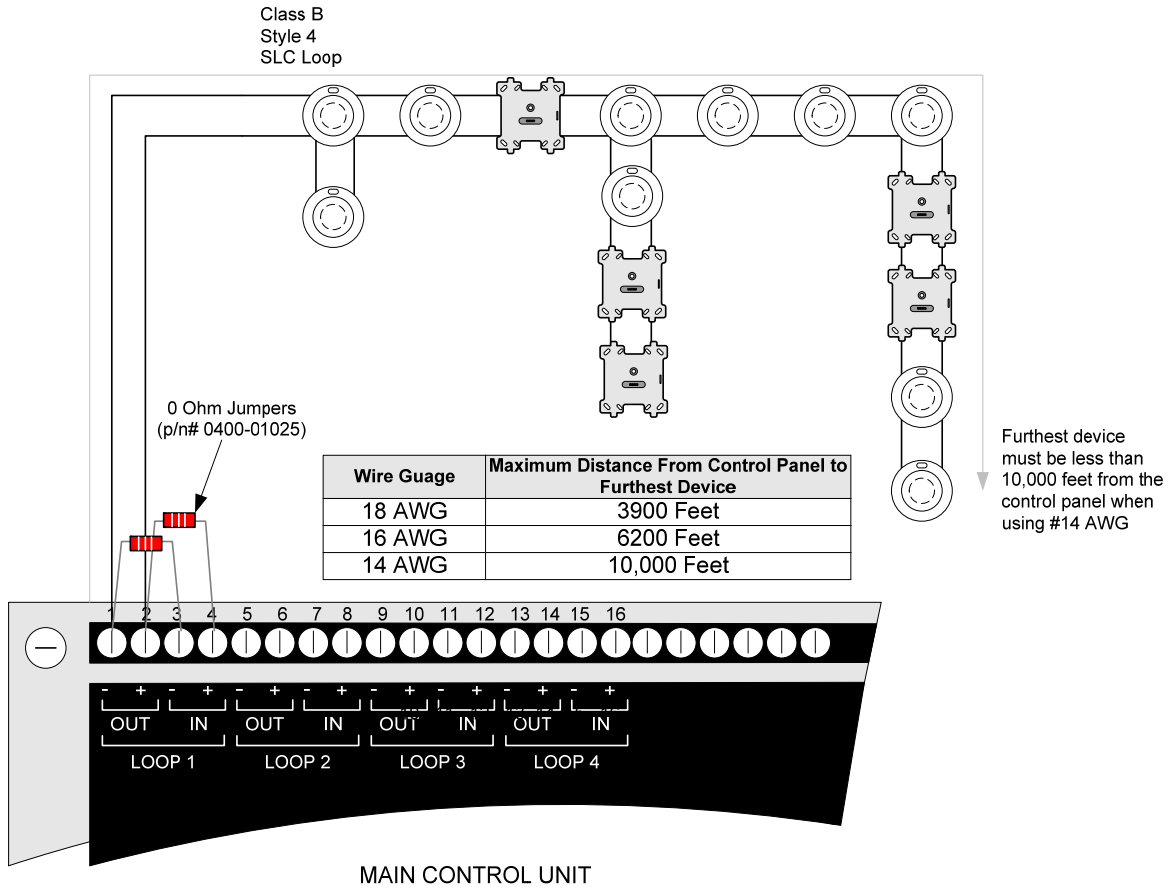
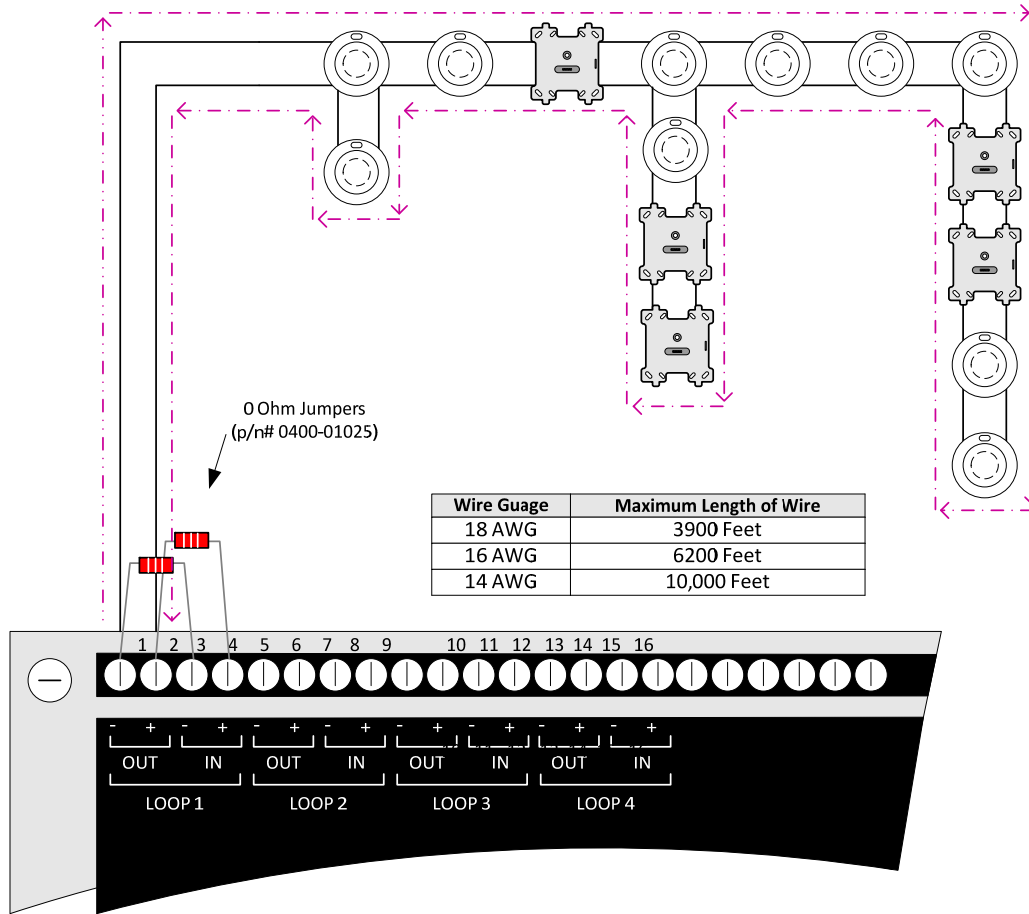

Figure 5.3.1 Maximum Wiring length for a Class B SLC



Class B SLC Loop (with T-taps)



The total SLC wire length is the sum of all circuits measured from the panel to the last device and back to the panel again. The maximum length must not exceed 10,000 feet when using 14 AWG wire.

**Figure 5.3.2 Maximum Wiring Length for a Class B SLC with T-Taps**

### 5.3.2 Class A SLC Loop Wiring Distance

Refer to Figure 5.3.3 to determine the maximum length of wire that may be used on a Class A signaling line circuit (SLC).

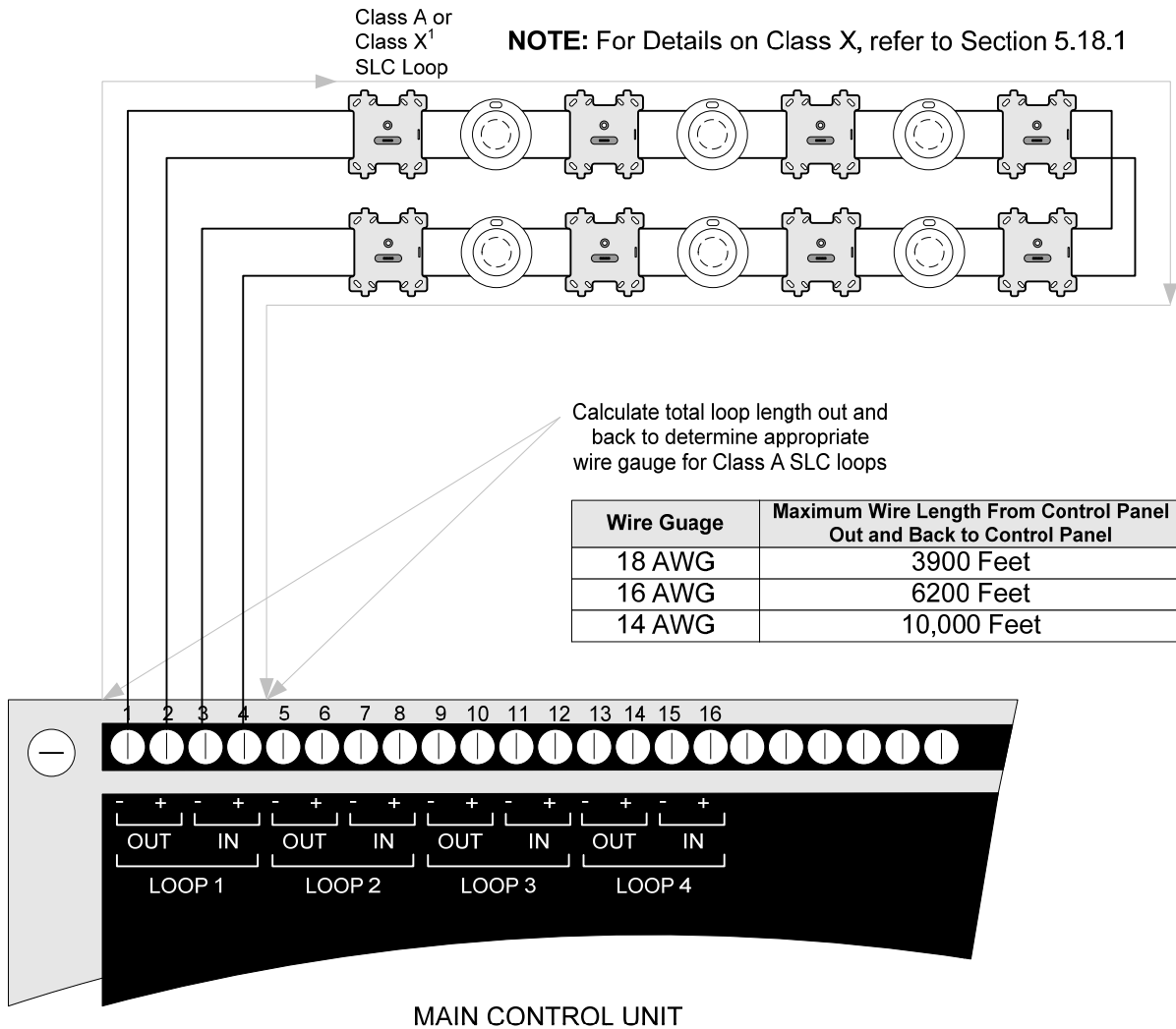

**Figure 5.3.3 Maximum Wiring Distance for a Class A SLC**

The SLC wiring must always meet the following requirements (per circuit):

- The total Resistance must be less than 50 ohms
- The total Capacitance must be less than 1 $\mu$ F
- The total Inductance must be less than 1mH

<sup>1</sup> – Class X circuits were previously designated “Class A Style 7” circuits. See Chapter 12 of NFPA 72, 2013 Edition.

## Additional Notes Regarding Class A and Class X 7 SLC loops:

- The total wire length must be measured as shown in Figure 5.3.4 below.

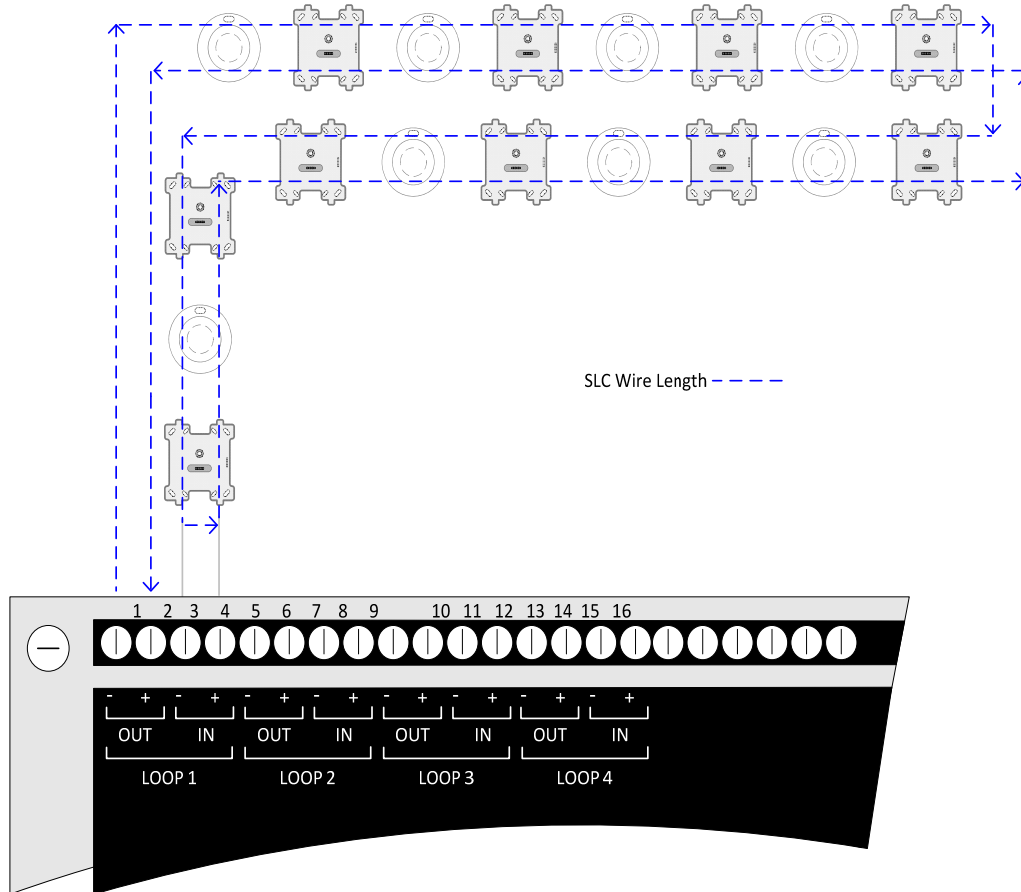

**Figure 5.3.4 Measuring SLC Total Wire Length for Class A Circuits**

- No t-taps are allowed on a Class A / Class X SLC loop.
- The return side of the loop must be routed separately from the outgoing loop.
- The return side may not share the same conduit or cable as the outgoing side of the SLC loop.
- When using Class X wiring, the SCI Short Circuit Isolators must be installed before and after each analog addressable device on the SLC loop. Alternately, analog devices with built-in SCI may be used. The wiring from the control panel to the first SCI and from the last SCI back to the control panel must be in conduit. Refer to Section 5.18 for more information on installing the SCI module and for installation methods to satisfy Class X criteria per NFPA 72.
- Refer to NFPA 72 for additional requirements of Class X circuits.

## 5.4 Addressing Devices

---

Prior to installation, all of the addressable devices installed on each of the FireNET 2127/4127 SLC loops must be programmed with a unique address ranging from 1 to 127. The analog sounder bases will automatically derive their address from the host sensor (detector) attached to them. The ASB address will be the sensor address + 127 (i.e.  $N + 127$ ). Example: The sensor address is 36.  $36 + 127 = 163$ . The ASB will have an address of 163. This address is what the FireNET 2127/4127 control panel uses to identify each addressable device and control its functionality. All Hochiki addressable devices come from the factory preset to address 127. This preset address can be reprogrammed using the Hochiki TCH-B100-NS programmer. Follow these instructions to set/reprogram the address.

1. Identify each analog addressable device that will be installed on an SLC loop and label it with a unique address ranging from 1 to 127.
2. Using the Hochiki TCH-B100-NS programmer as shown in Figure 5.4, program the appropriate address into each analog addressable device.

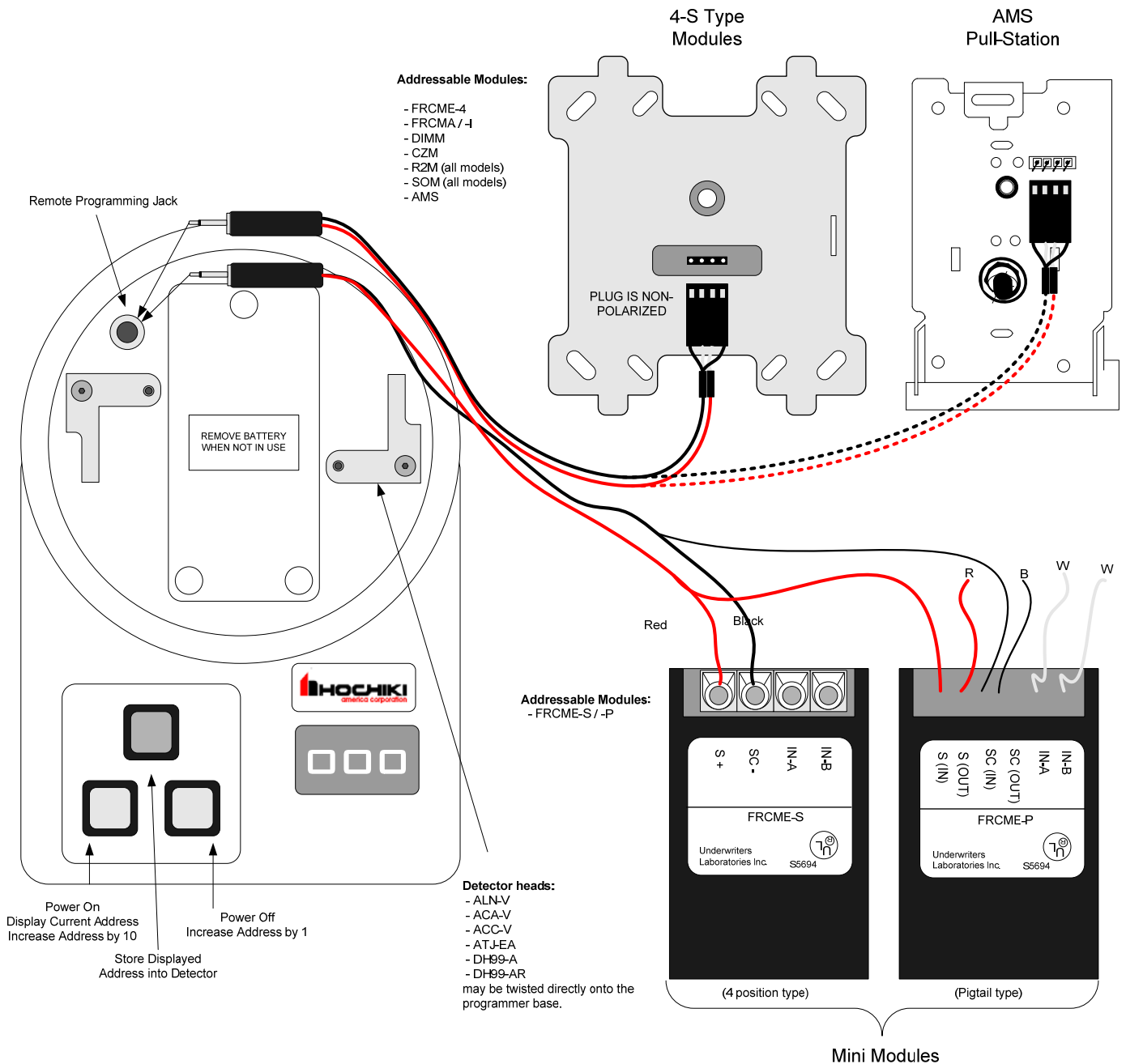

**Figure 5.4 Hochiki TCH-B100-NS Programmer Connections**

1. ASB Automatically derives its address from host sensor (N + 127).
2. Devices must not be powered when using the TCH-B100-NS programmer to set addresses.
3. Mini-modules such as the FRCME-S and FRCME-P should not be connected to the SLC loop when using the TCH-B100-NS programmer to set addresses.
4. When programming the AMS, use the same method as the 4-S type addressable modules.

## 5.4.1 Detector Addressing

This section applies to the following Hochiki analog detectors – ALN-V, ACC-V, ATJ-EA, DH-99-A, DH-99-AR,. Follow these steps to program a new address into any one of these analog detectors. (Refer to Figure 5-4)

1. Twist an analog detector head on to the programmer terminals.
2. Press the left gray button to turn on the programmer and read/display the current address in the detector head. (Factory default is address 127)
3. Using the left gray button you can increase the tens digit one number at a time. Using the right gray button you can increase the ones digit one number at a time. Using these buttons change the displayed address to the appropriate value.
4. Press the red button to store the displayed address into the detector head.

## 5.4.2 4-S Module and AMS Addressing

This section applies to the following Hochiki addressable modules - FRCME-4, FRCMA, FRCMA-I, R2M (all models), DIMM, CZM, SOM (all models), and AMS. Follow these steps to program a new address into any of these addressable modules. (Refer to Figure 5-4)

1. Using the dual-end programming plug provided with the programmer, plug one end into the jack on the programmer and plug the other end into the programming plug located on the front of the module plate. The plug is non-polarized and can be connected in either orientation.
2. Press the left gray button to turn on the programmer and read/display the current address in the module.
3. Using the left gray button you can increase the displayed address 10 numbers at a time. Using the right gray button you can increase the displayed address one number at a time. Using these buttons change the displayed address to the appropriate value.
4. Press the red button to store the displayed address into the addressable module.

### 5.4.3 Mini Module Addressing

This section applies to the Hochiki FRCME-S, FRCME-P and FRCME-M addressable mini-module. Follow these steps to program a new address into any of these addressable modules. (Refer to Figure 5-4)

1. Using the single ended programming plug, plug the end with the jack on it into the programming jack on the programmer. The programming plug with alligator clips may also be used.
2. Connect the Red wire of the single ended programming plug into the terminal labeled **S (IN)** on the addressable module. Connect the Black wire of the single ended programming plug into the terminal labeled **SC (IN)** on the addressable module.
3. Press the left gray button to turn on the programmer and read/display the current address in the module.
4. Using the left gray button you can increase the displayed address 10 numbers at a time. Using the right gray button you can increase the displayed address one number at a time. Using these buttons change the displayed address to the appropriate value.
5. Press the red button to store the displayed address into the addressable module.

## 5.5 Smoke and Heat Detector Wiring

All FireNET analog detectors must be installed using a base.

For detailed instructions on the physical mounting of FireNET analog smoke and heat detectors please refer to the installation instructions that are included with each analog detector.

Prior to installing any analog detector or module you must set its address as described in section 5.4.

Wire the analog smoke and heat detector bases as indicated in Figure 5.5.

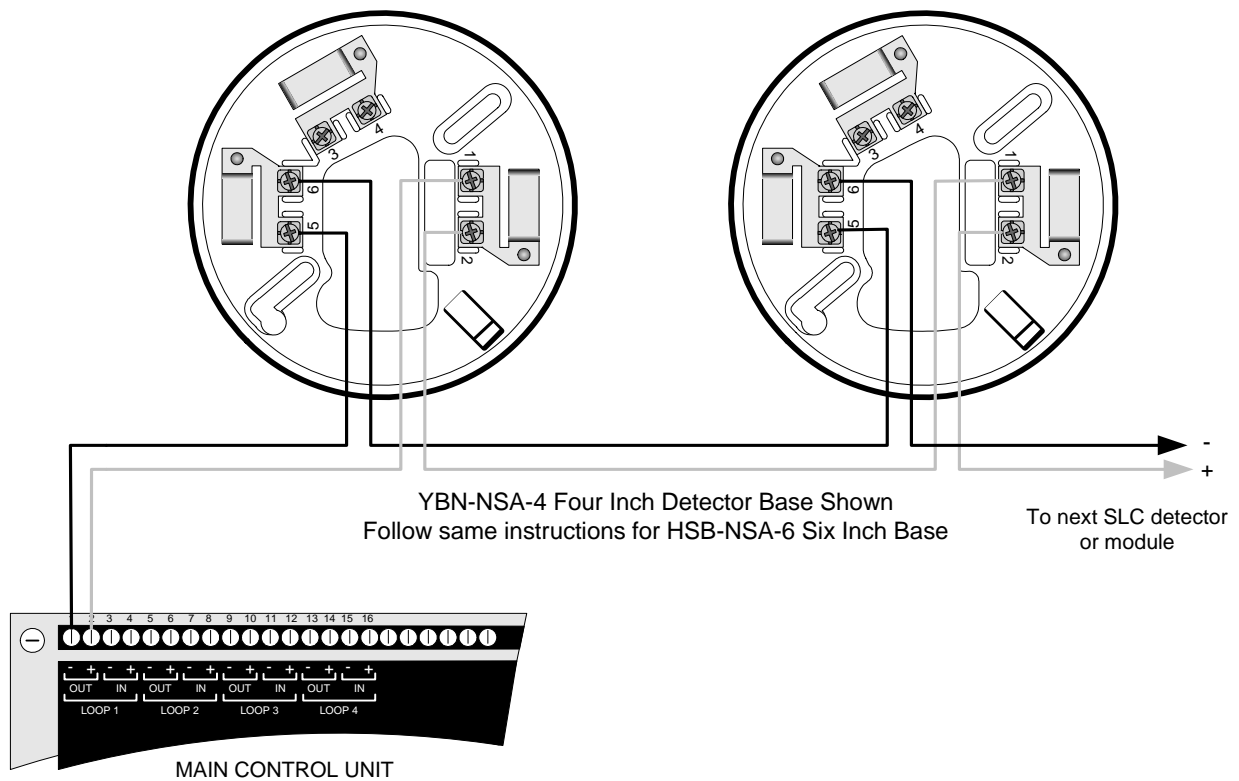

Figure 5.5 Analog Detector Base Wiring



## ***5.6 Analog Duct Detector Wiring***

---

This section includes wiring instructions for connecting the DH98-A, DH-98-AR, DH-99-A, and DH-99-AR analog duct detectors to the FireNET 2127/4127 control panel SLC loop.

For detailed instructions on the physical mounting and wiring of FireNET analog duct detectors please refer to the installation instructions that are included with each device.

Prior to installing any analog detector or module you must set its address as described in section 5.4. You will need to remove the smoke detector head from the base in the duct detector in order to program it.

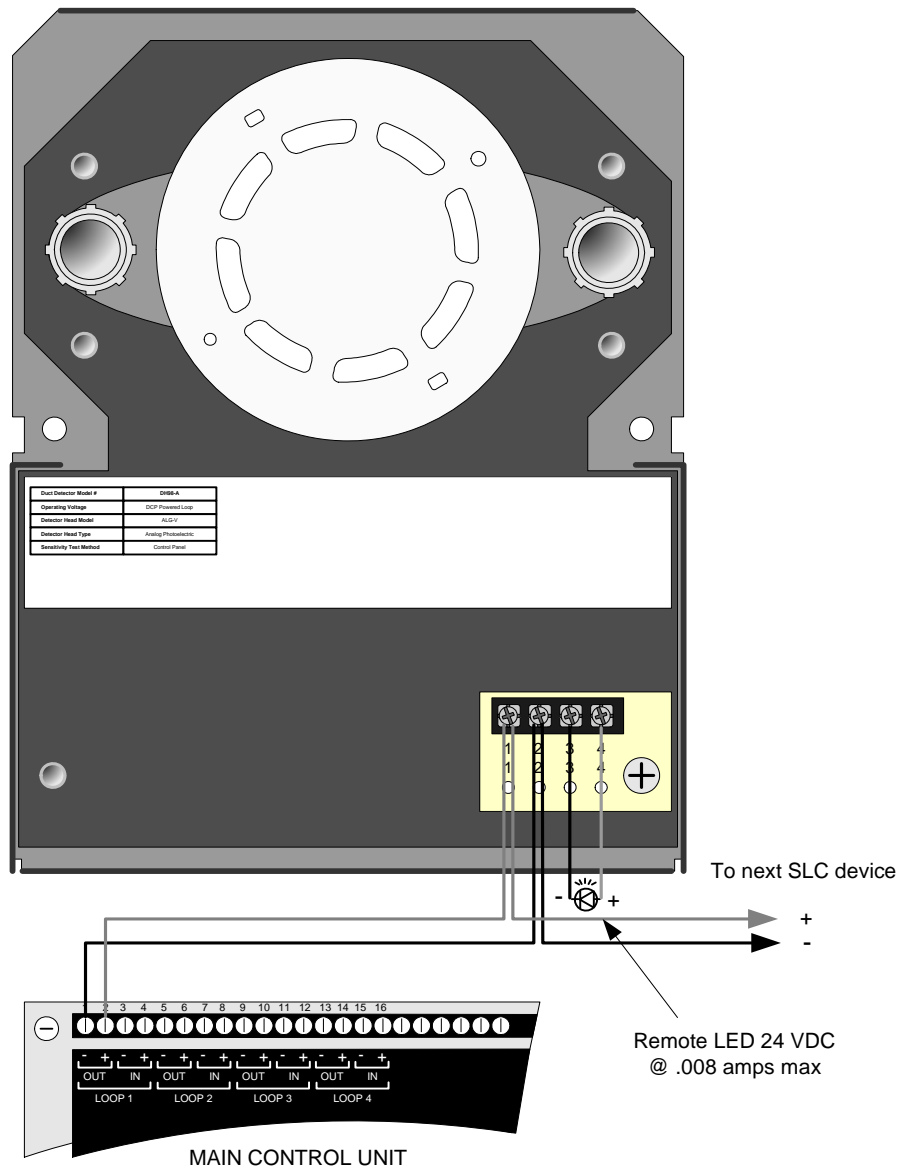

**Figure 5.6.1 DH98-A**

### 5.6.1 DH98-A Analog Duct Detector

Connect the DH98-A analog duct detector to the FireNET 2127/4127 control panel SLC loop as shown in Figure 5.6.1.

Terminals 3 and 4 can be used to power a remote alarm LED. The ratings on these terminals are 24 VDC at .008 amps maximum. Please note the number of alarm LED's that can be illuminated at one time is limited to 5 addresses per SLC loop by the control panel.

**NOTE:** The duct sensor LED and remote LED output only activate momentarily when in alarm.

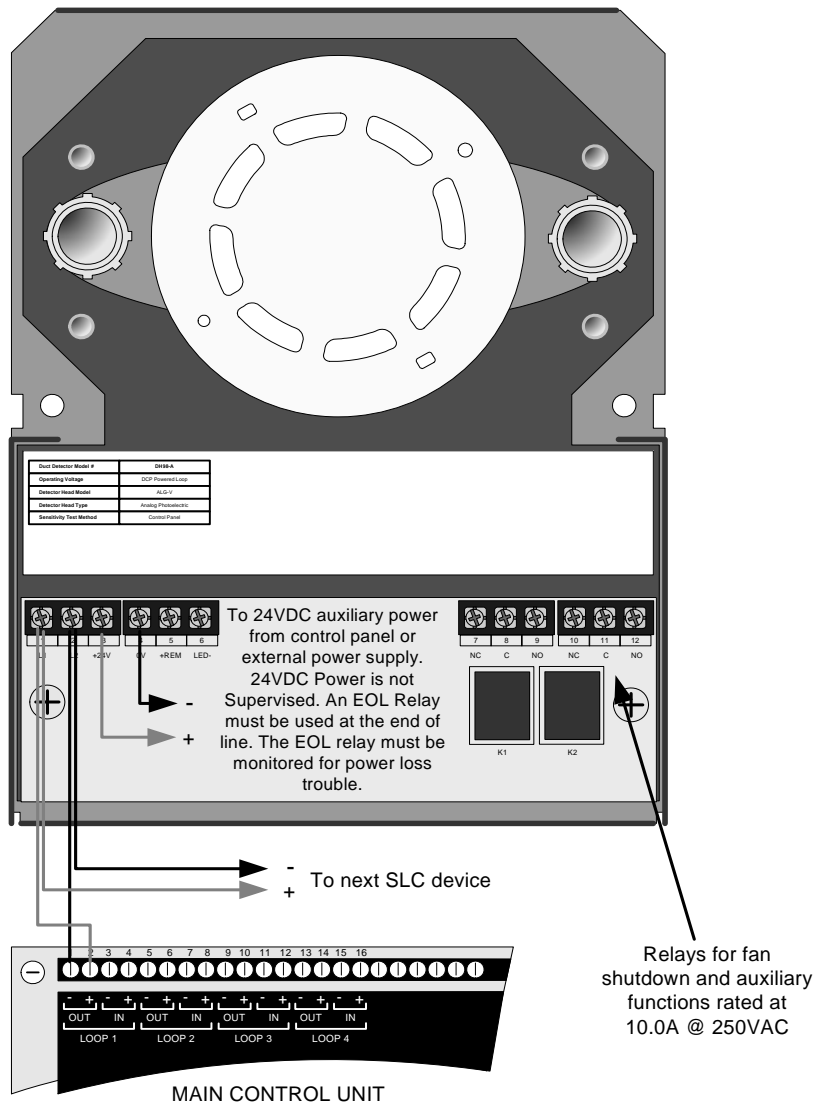

**Figure 5.6.2 DH98-AR**

### 5.6.2 DH98-AR Analog Duct Detector with Relay

Connect the DH98-AR analog duct detector with relays, to the FireNET 2127/4127 control panel as shown in Figure 5.6.2.

In addition to the SLC loop connections, the DH98-AR requires 24-volt reset-able auxiliary power (10mA standby and 55mA alarm) connected to terminals 3+ and 4-. This power may come from the FireNET 2127/4127 main control panel auxiliary power (500 mA max.) connections (terminals 18 and 19) or from an external power supply.

The DH98-AR analog duct detector contains 2 sets of form C alarm contacts rated at 10.0 amps @ 250 VAC that can be used for fan shutdown and other auxiliary functions.

In addition to the alarm contacts the DH98-AR also has connections for a remote test switch as well as outputs for a remote alarm and remote pilot light LED's.

**NOTE:** Test switch only activates output relays, and does not place the detector into alarm.

## 5.7 FRCME-4 Input Module Wiring

The FRCME-4 input module is used to connect standard normally open dry contact types of fire alarm devices such as pull stations, waterflow, or tamper switches to the FireNET 2127/4127 SLC loop. More than one switch can be connected to a FRCME-4 however you must not mix multiple switch types on a single FRCME-4. *For example: three waterflow switches connected to a single FRCME-4 is acceptable. However, two waterflow switches and one valve tamper switch connected to a single FRCME-4 is not.* NFPA and local codes may also apply.

The FRCME-4 must be programmed with a unique address from 1-127. All of the switches connected to a single FRCME-4 appear at the main control panel as a single address. Please refer to section 5.4 of this manual for instructions on programming an address into the FRCME-4 input module.

Connect the FRCME-4 to the FireNET as shown in figure 5.7.1. Refer to the installation instructions included with the FRCME-4 for more detailed installation and wiring instructions.

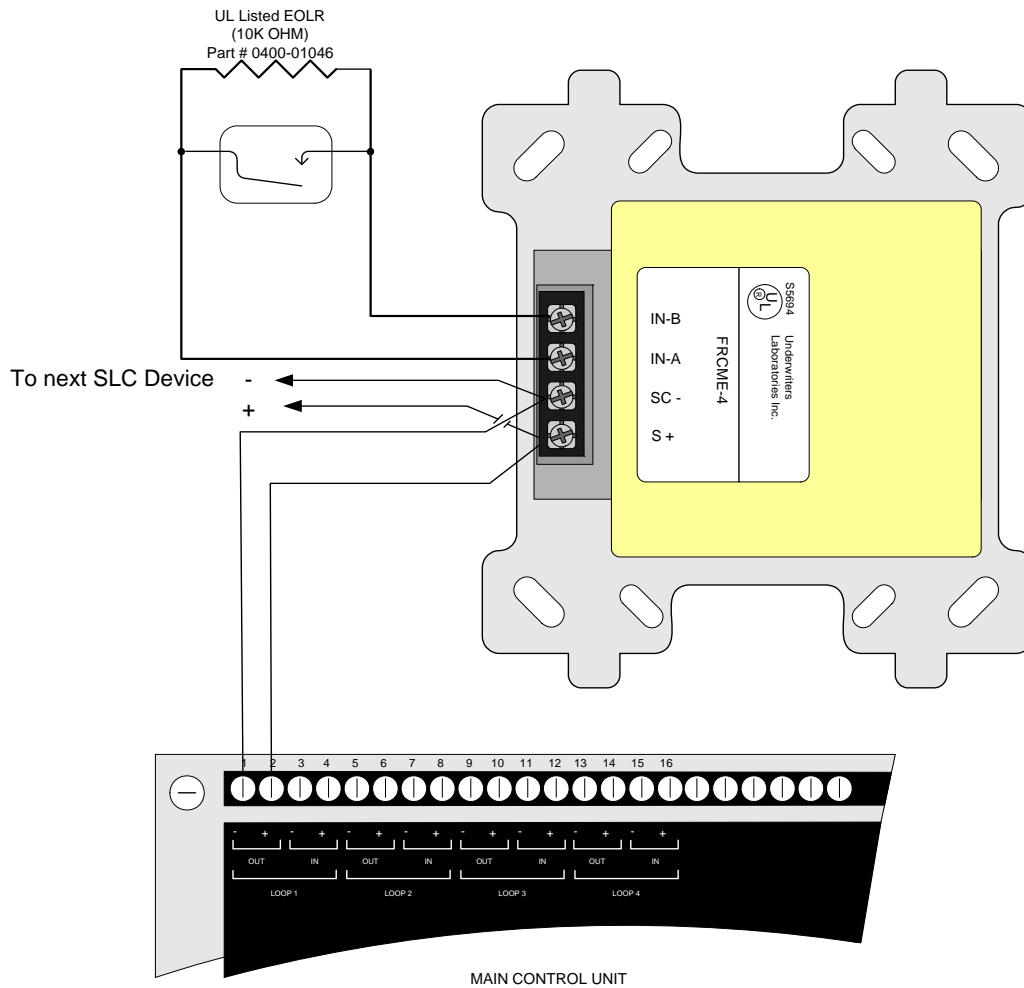

Figure 5.7.1 FRCME-4 Input Module Wiring Detail

## 5.8 FRCME-S Mini Input Module (w/ Terminal Blocks)

The FRCME-S input module is used to connect standard normally open dry contact types of fire alarm devices such as manual pull stations to the FireNET 2127/4127 SLC loop.

The FRCME-S must be programmed with a unique address from 1-127. All of the dry contact type devices connected to a single FRCME-S appear at the main control panel as a single address. Please refer to section 5.4 of this manual for instructions on programming an address into the FRCME-S input module.

Connect the FRCME-S to the FireNET as shown in figure 5.8.1. Refer to the installation instructions included with the FRCME-S for more detailed installation and wiring instructions.

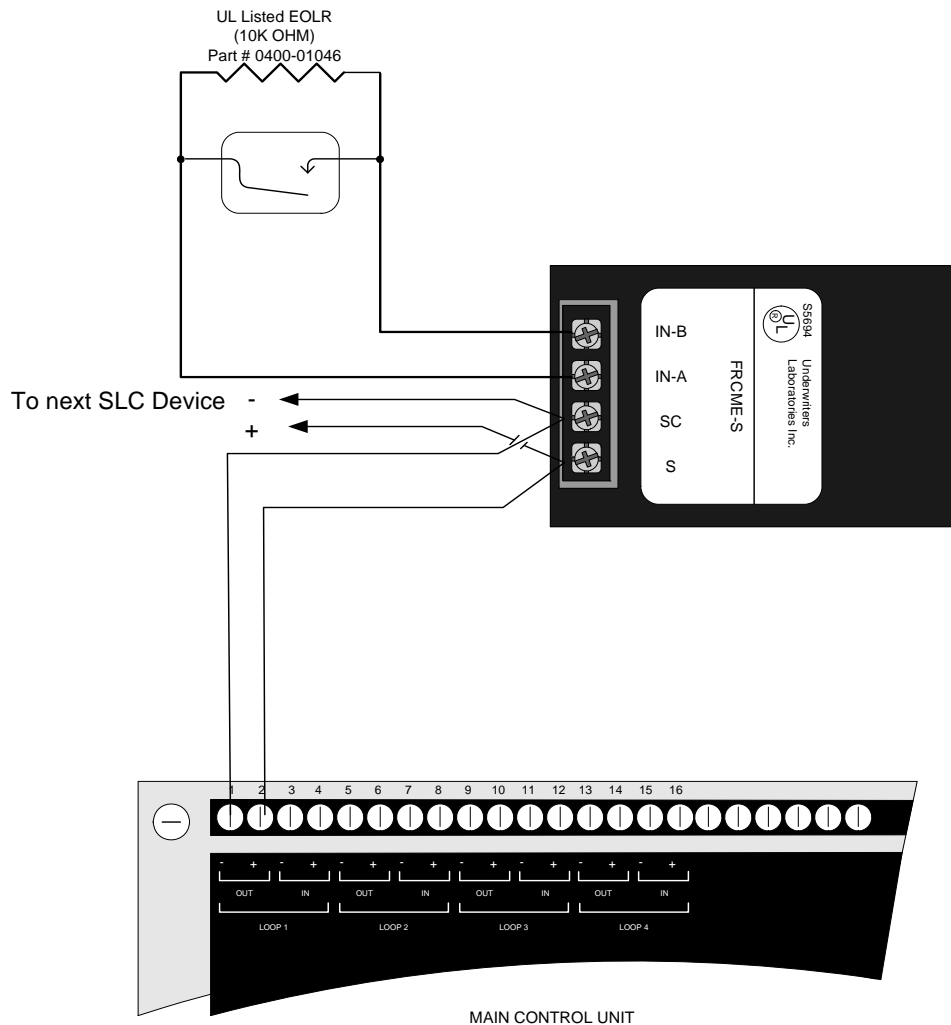

**Figure 5.8.1 FRCME-S Mini Input Module (w/ Terminal Blocks) Detail**

**NOTE:** The FRCME-S has been tested to or evaluated to UL 864 8<sup>th</sup> edition. However, the FRCME-S will operate with the 9<sup>th</sup> edition listed FireNET Fire Alarm Control panel. Therefore, it may be used in panel retrofit applications, subject to approval by your AHJ.

## 5.9 FRCME-P Mini Input Module (w/ Pigtailed)

The FRCME-P input module is used to connect standard normally open dry contact types of fire alarm devices such as manual pull stations to the FireNET 2127/4127 SLC loop.

The FRCME-P must be programmed with a unique address from 1-127. All of the dry contact type devices connected to a single FRCME-P appear at the main control panel as a single address. Please refer to section 5.4 of this manual for instructions on programming an address into the FRCME-P input module.

Connect the FRCME-P to the FireNET as shown in figure 5.9.1. Refer to the installation instructions included with the FRCME-P for more detailed installation and wiring instructions.

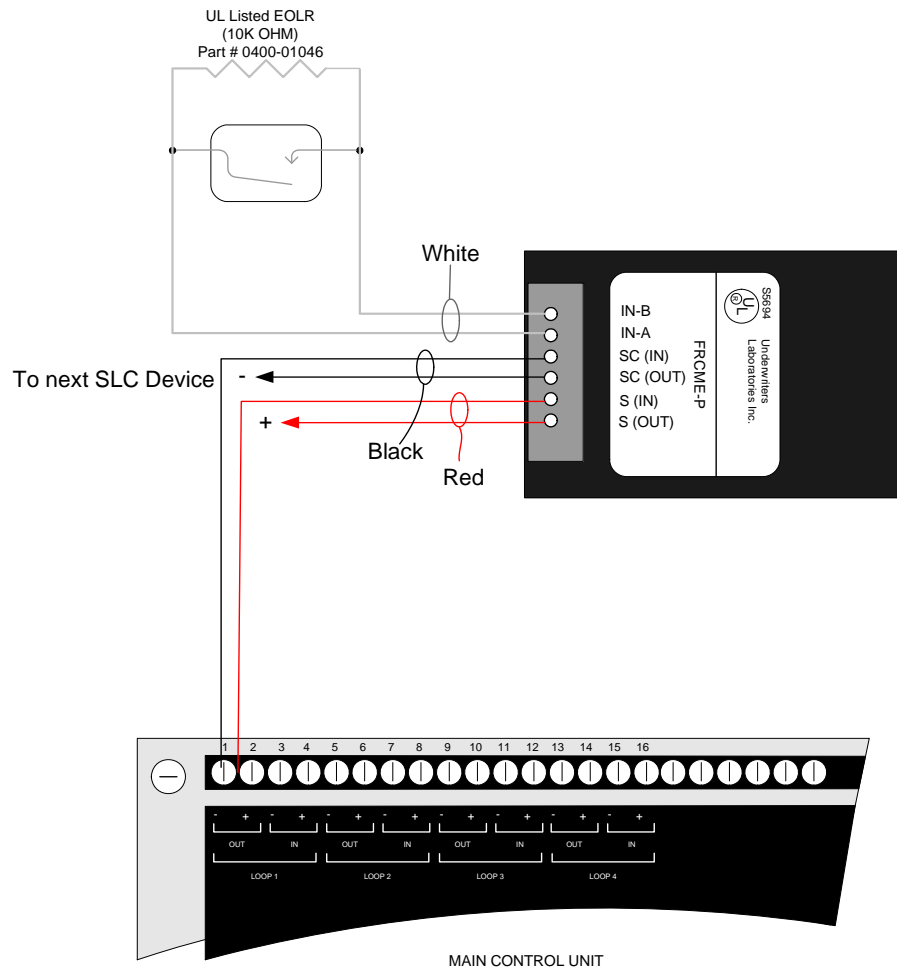

Figure 5.9.1 FRCME-P Mini Input Module (w/ Pigtailed) Detail

NOTE: The FRCME-P/55-019 has been tested to UL 864 8<sup>th</sup> edition. However, the FRCME-P/55-019 will operate with the 9<sup>th</sup> edition listed FireNET Fire Alarm Control panel. Therefore, it may be used in panel retrofit applications, subject to approval by your AHJ.

## 5.10 FRCME-M Mini Input Module (w/ Terminal Blocks)

The FRCME-M input module is used to connect standard normally open dry contact types of fire alarm devices such as manual pull stations to the FireNET 2127/4127 SLC loop.

The FRCME-M must be programmed with a unique address from 1-127. All of the dry contact type devices connected to a single FRCME-S appear at the main control panel as a single address. Please refer to section 5.4 of this manual for instructions on programming an address into the FRCME-M input module.

Connect the FRCME-M to the FireNET as shown in figure 5.10.1. Refer to the installation instructions included with the FRCME-M for more detailed installation and wiring instructions.

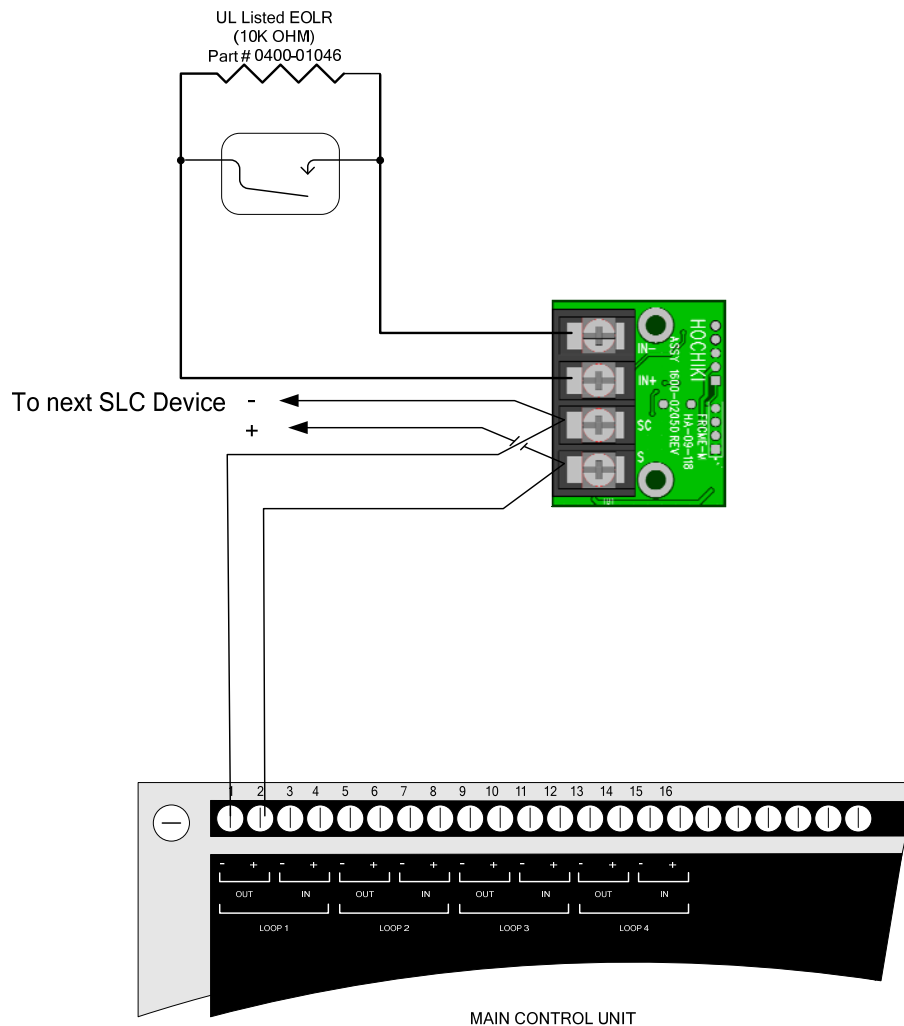

Figure 5.10.1 FRCME-M Mini Input Module (w/ Terminal Blocks) Detail

## 5.11 FRCMA / FRCMA-I Input Module

The FRCMA / FRCMA-I input module is used to connect standard normally open dry contact types of fire alarm devices such as manual pull stations to the FireNET SLC loop. The FRCMA module provides one class A or one class B input circuit. The FRCMA-I includes built-in short circuit isolation for the SLC loop.

The FRCMA must be programmed with a unique address from 1-127. All of the dry contact type devices connected to a single FRCMA are displayed at the main control panel as a single address. Please refer to section 5.4 of this manual for instructions on programming an address into the FRCMA input module.

Connect the FRCMA to the FireNET as shown in figure 5.11.1. Refer to the installation instructions included with the FRCMA for more detailed installation and wiring instructions.

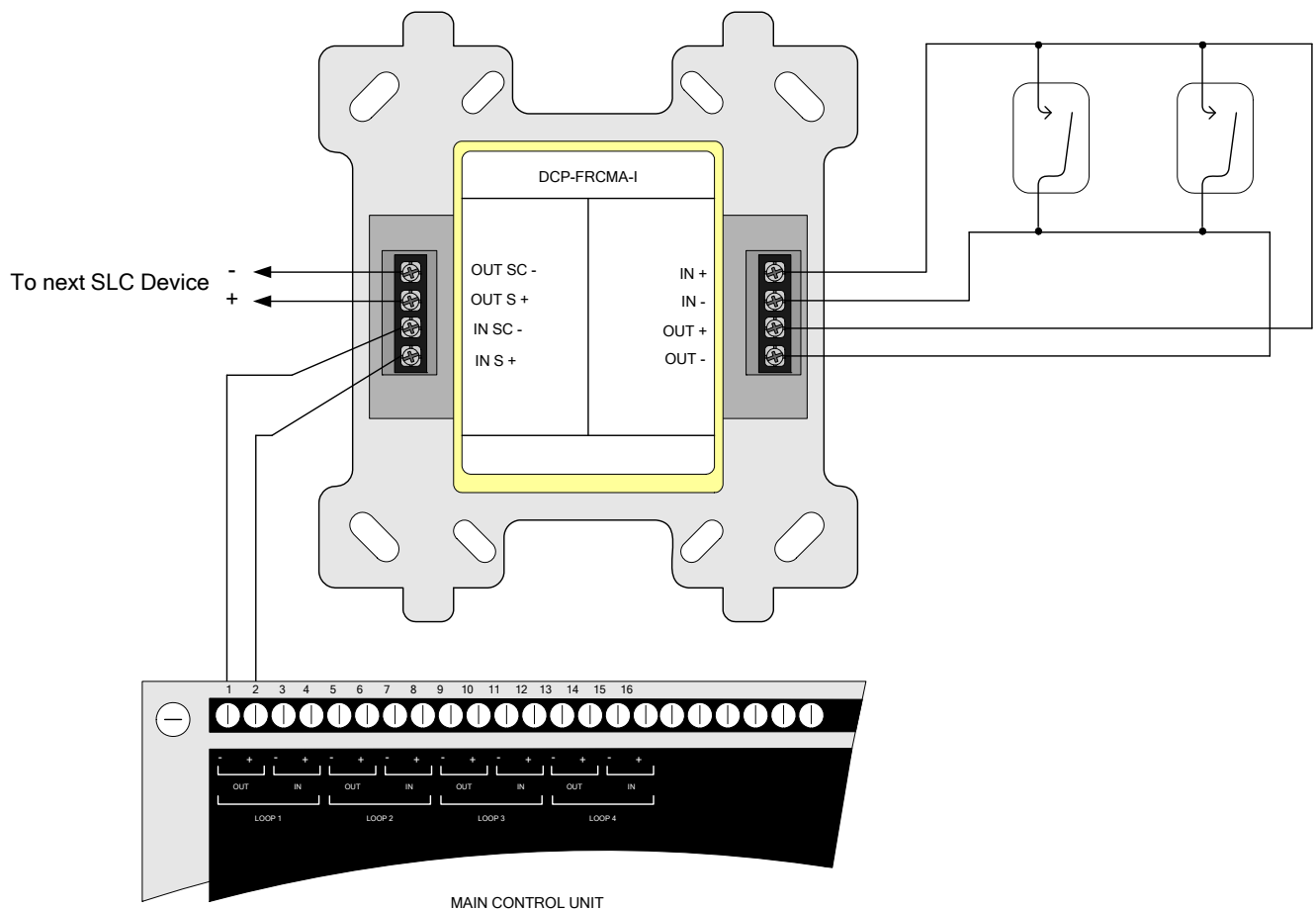

Figure 5.11.1 FRCMA-I Input Module Class A Detail



**NOTE: For Sections 5.7 – 5.11 common for all FRCM devices –**

Reference the input wiring distance limitation table below for all types of FRCM modules:

Maximum Distance Between Module and EOL Device	
14 AWG	1500 Ft.
16 AWG	900 Ft.
18 AWG	550 Ft.

## 5.12 R2M Dual Relay Module Wiring

The R2M provides two separately programmable relay outputs on the FireNET 2127/4127 SLC loop. These outputs may be used for a variety of purposes including door holders, elevator recall, and other fire safety functions.

The programmable relay contacts are rated as follows

- **R2M** - 1.0A @ 30VDC or 0.5A @ 125VAC, 0.35 Power Factor (PF)
- **R2ML/R2ML-I** – 2.0A @ 30VDC, 1PF or 0.5A @ 120VAC, 0.6PF
- **R2MH/R2MH-I** – 8.0A @ 30VDC or 8.0A at 250VAC Resistive, 1.0PF or 4.8A @ 250VAC, 0.6PF.

The R2ML-I and R2MH-I modules have built-in Short Circuit Isolation (SCI) for the SLC loop.

Connect the R2M as shown in Figure 5.12.1. Refer to the installation instructions included with the R2M for more detailed wiring and installation instructions.

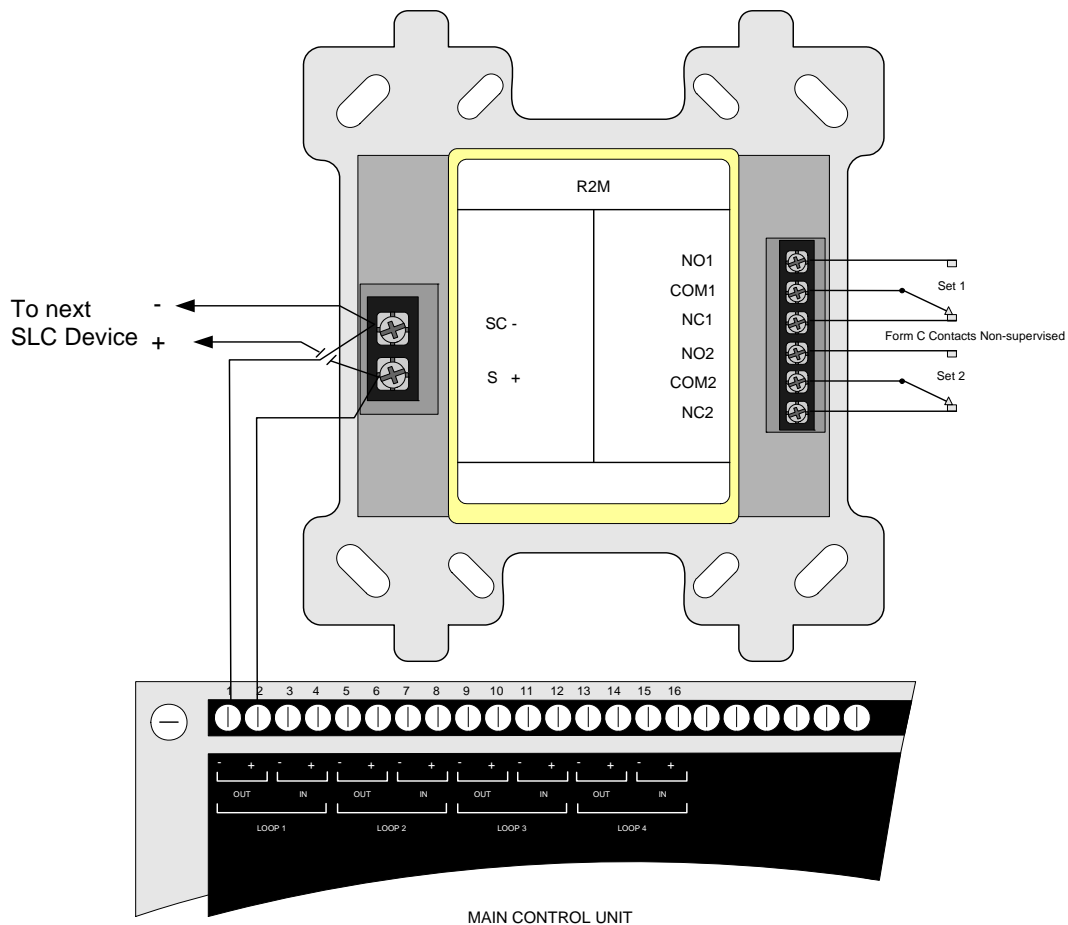

Figure 5.12.1 R2M Dual Relay Module Wiring Detail

## 5.13 SOM Supervised Output Module

The SOM provides a supervised 24VDC polarity reversing output on the SLC loop most commonly used for audible and visual signaling appliances or triggering a remote notification appliance circuit power expander.

In addition to the SLC circuit the SOM requires a 24 VDC auxiliary input voltage. This voltage may be connected to the FN-2127/4127 control panel terminals 18 and 19 (500ma max) or to any other UL listed fire alarm power supply providing 24 VDC.

The supervised voltage output of the SOM is rated at 2.0A maximum.

Connect the SOM to the FN-2127/4127 control panel as shown in Figure 5.13.1. Refer to the installation instructions included with the SOM for more detailed wiring and installation instructions. Take care to install wiring so that faults on installation conductors do not affect more than one notification zone. The DCP-SOM is suitable for use only with non-synchronized audible devices.

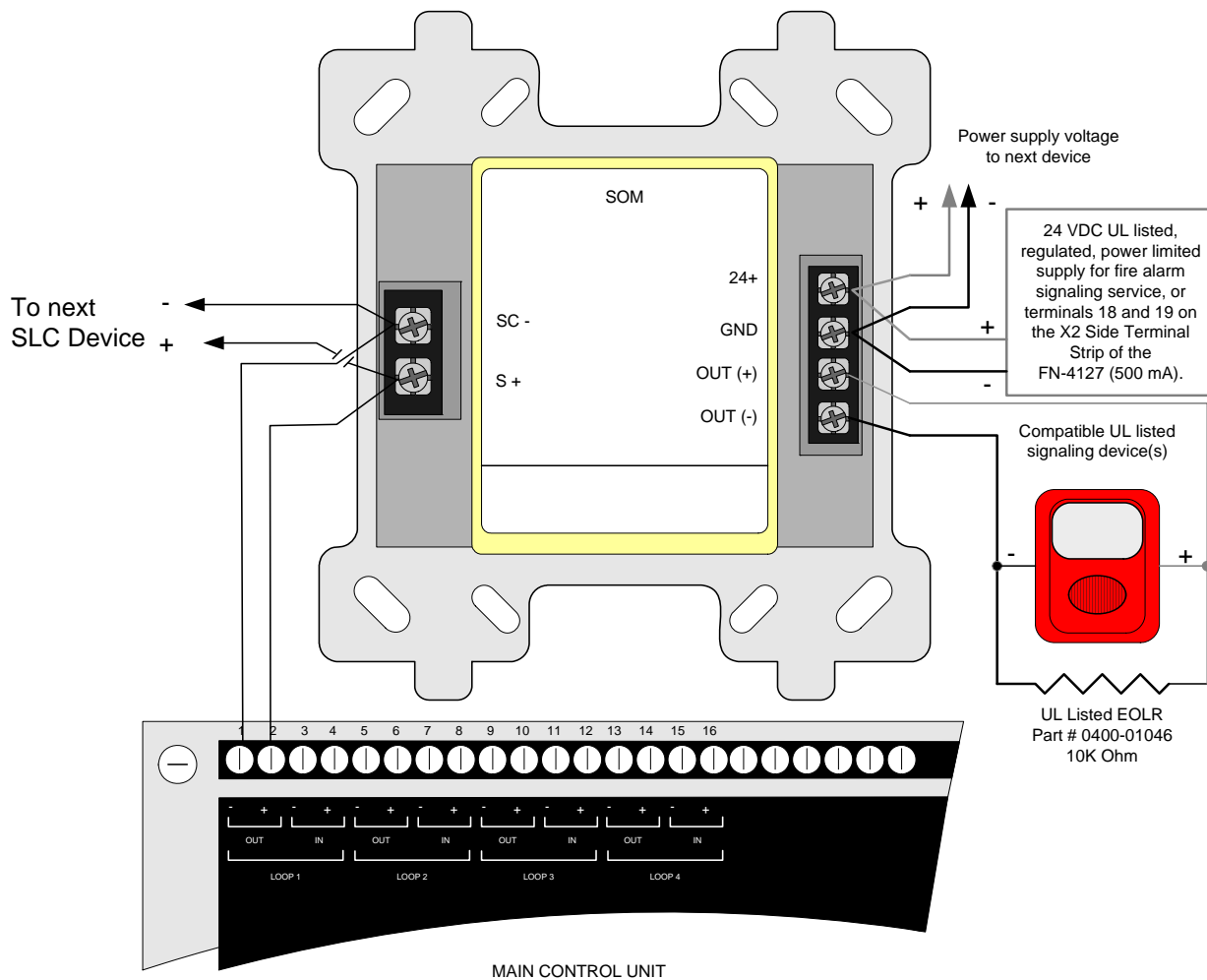

Figure 5.13.1 SOM Supervised Output Module Detail

## 5.14 SOM-A / SOM-AI Supervised Class A Output Module

The SOM-A / SOM-AI provides a supervised 24VDC polarity reversing Class A output on the SLC loop. This module is most commonly used for audible and visual signaling appliances or for triggering a remote notification appliance circuit power expander. The SOM-AI includes built-in short circuit isolation (SCI).

In addition to the SLC circuit the SOM-A / SOM-AI requires a 24 VDC auxiliary input voltage. This voltage may be connected to the FN-2127/4127 control panel terminals 18 and 19 (500ma max) or to any other UL listed fire alarm power supply providing 24 VDC. The supervised voltage output of the SOM-A / SOM-AI is rated at 2.0A maximum.

Connect the SOM-AI to the FN-2127/4127 control panel as shown in Figure 5.14.1. Note that the SLC connections for the SOM-A are like the SOM; there is only one S+ and one SC-terminal. Refer to the installation instructions included with the SOM-A / SOM-AI for more detailed wiring and installation instructions. Take care to install wiring so that faults on installation conductors do not affect more than one notification zone. The SOM-A / SOM-AI is suitable for use only with non-synchronized audible devices.

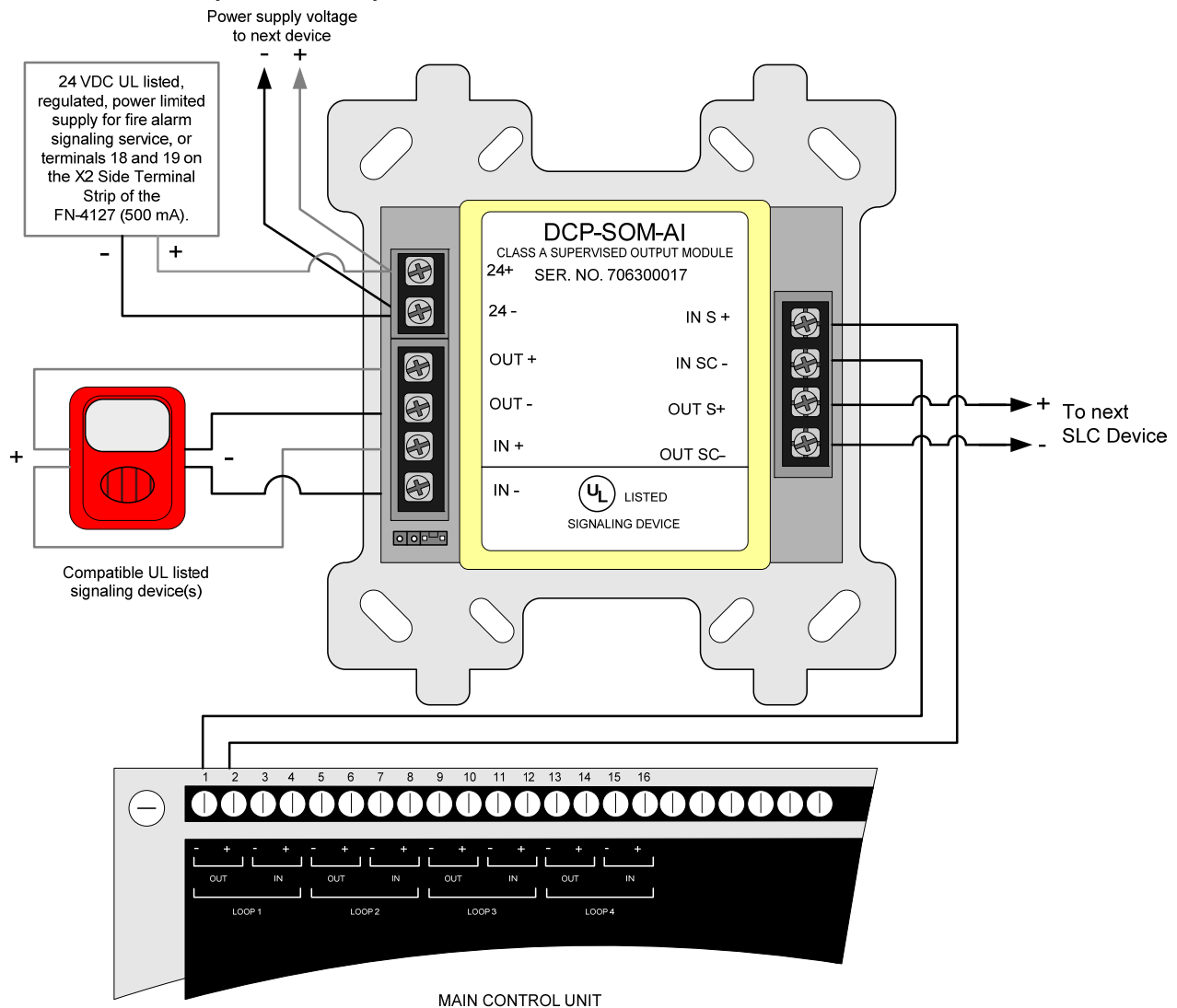

Figure 5.14.1 SOM-AI Supervised Output Module Detail

## 5.15 SOM-R Supervised Output Module (Preaction Sprinkler Systems)

The SOM-R provides a supervised 24VDC output on the SLC loop for use with solenoids used in a single interlock, preaction sprinkler system.

The SOM-R consists of an output module, a polarized end-of-line device, and a keyswitch module that is used to disable the output of the SOM-R.

The SOM-R requires connections to the SLC and a 24 VDC auxiliary input voltage. The keyswitch disable module must be connected to the SLC and to the output of the SOM-R module.

The supervised voltage output of the SOM-R is rated at 2.0A maximum.

The alarm time for the SOM-R battery calculation shall be 5 minutes in the “active status”.

*NOTE: These installation instructions must be followed completely in order to comply with agency requirements! Failure to follow these installation instructions may result in improper operation of the SOM-R.*

1. Determine the mounting location for the SOM-R, FRCME and SOM-R-DS keyswitch. These should be installed in the same location, or as required by your AHJ.

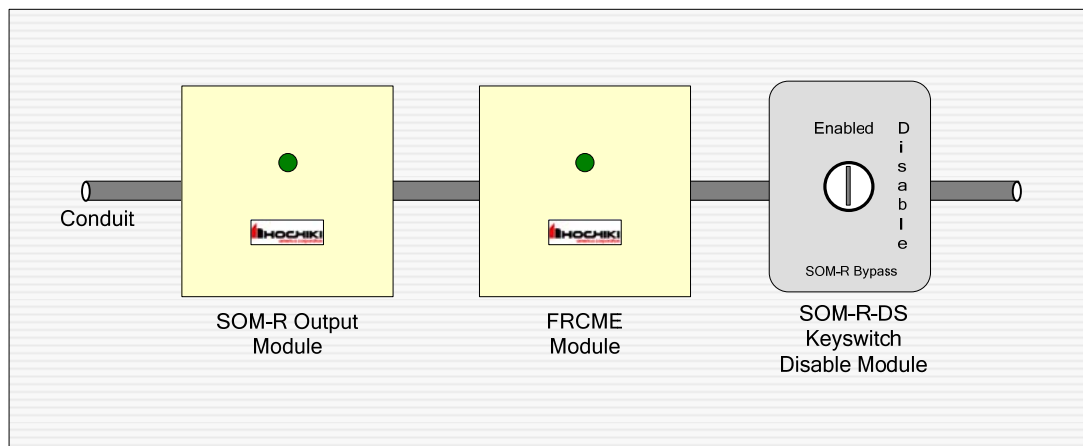

2. The SOM-R must be addressed using the TCH-B100 programmer. Connect the SOM-R to the FN-2127/4127 SLC as shown in Figure 5.15.1. Refer to the installation instructions (Part # 1700-11320, Rev. 05/10) included with the SOM-R for additional wiring and installation instructions.

3. Connect 24VDC power to the SOM-R module. This voltage may be provided by; 1) a UL 1481 listed, regulated, power limited supply, 2) a FN-2127/4127 NAC circuit configured as continuous auxiliary power, or 3) the FN-2127/4127 aux power on X2 terminals 18 and 19 (500ma max).

4. The SOM-R-DS keyswitch connected to the FRCME module must be connected to the FireNET SLC. Use the TCH-B100 programmer to assign an address to the module and then connect the SLC circuit to the S+ and SC- terminals on the module.

5. Connect the output of the SOM-R to the input terminals on the SOM-R-DS keyswitch connected to the FRCME module. Ensure correct polarity.

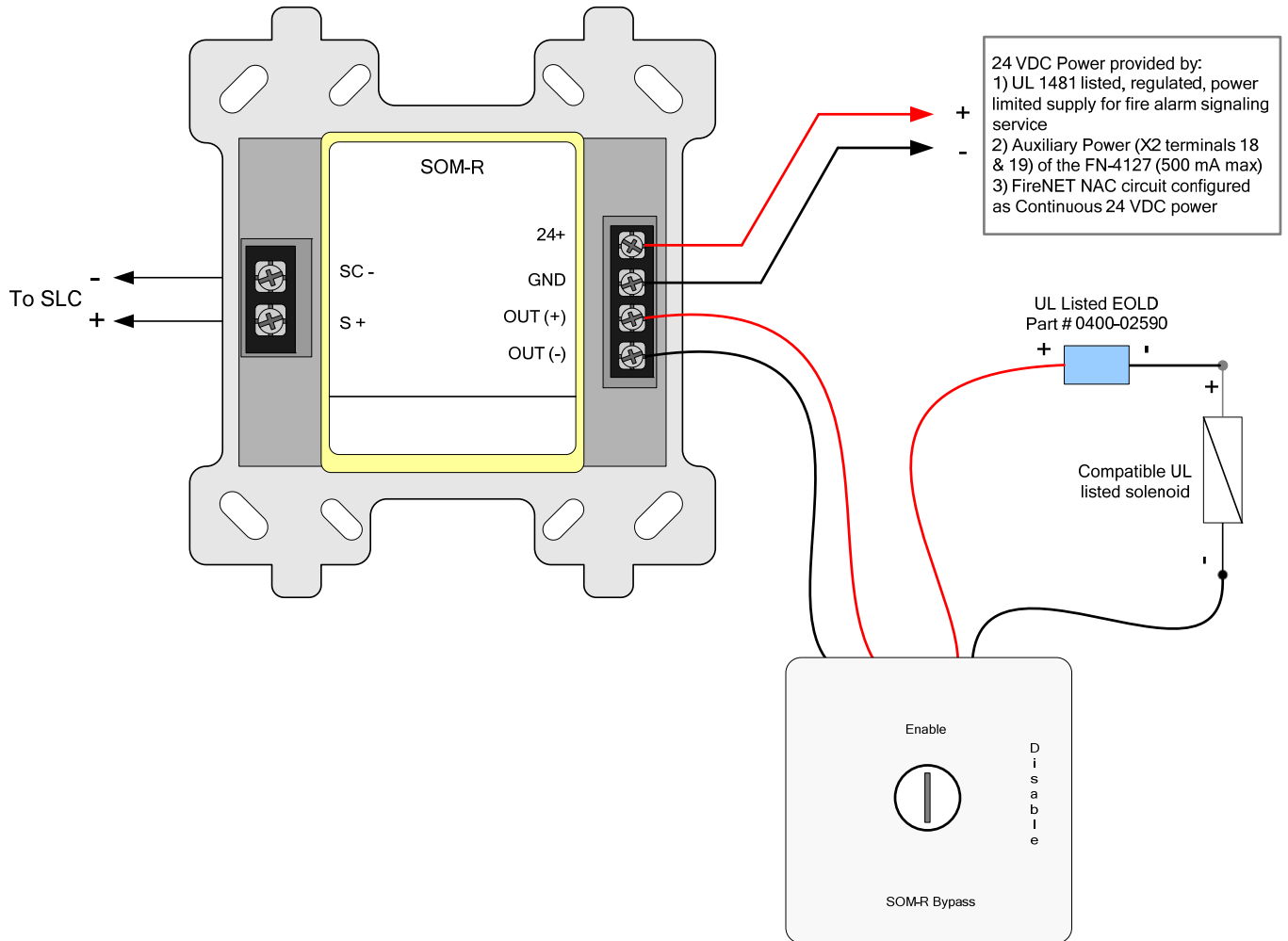

**Figure 5.15.1 SOM-R Supervised Output Module Detail**

6. Connect the output terminals on the keyswitch disable module to the solenoid. Ensure that the EOLD is properly connected to the circuit as shown in Figure 5.15.1 above.

**Operation of the SOM-R**

The SOM-R is designed for use with single interlock preaction sprinkler systems. When the FireNET control panel detects a fire alarm condition from a single initiating point, the SOM-R will be activated, allowing water to flow into the sprinkler piping. Water is not discharged from a sprinkler head until increased temperature from the fire activates the sprinkler head.

Output delays are not applied to the activation of the SOM-R. The SOM-R output is activated immediately upon detection of a fire condition by the FireNET control panel.

**Important!** For proper operation, program the SOM-R Output Attributes as follows:

- Gen Alarm Mode = YES
- Silenceable = NO
- Emergency = NO
- Pre Alarm = NO
- Trouble = NO
- Pattern = CONTINUOUS
- Edit Location Text = SOMR

Program the FRCME attributes as follows:

- Set Input Type = GEN PURPOSE N/C EOL
- Set Input Action = SUPERVISORY
- Set Input Latch = NO
- Set Input Delay = 0s
- Edit Location Text = SOMR IS DISABLED

Other settings may be assigned as needed.

**Failure to follow these programming instructions may result in incorrect operation of the SOM-R module!**

**NOTE:** The location text will need to be programmed to state “**SOMR PREACTION DISCHARGE**” for all initiating devices, which activates the SOM-R module.

**Alarm Verification may not be used with the SOM-R.**

**NOTE:** Only one solenoid may be connected to the SOM-R. DO NOT CONNECT MULTIPLE SOLENOIDS TO THE SOM-R OUTPUT CIRCUIT!

To Disable the SOM-R:

Move the keyswitch to the “SOM-R Disabled” position.

To Enable the SOM-R:

Return the keyswitch to the “SOM-R Enabled” position.

**NOTE: DO NOT DISABLE THE SOM-R OR KEYSWITCH MODULE BY USING THE DISABLEMENTS MENU ON THE FIRENET CONTROL PANEL!**

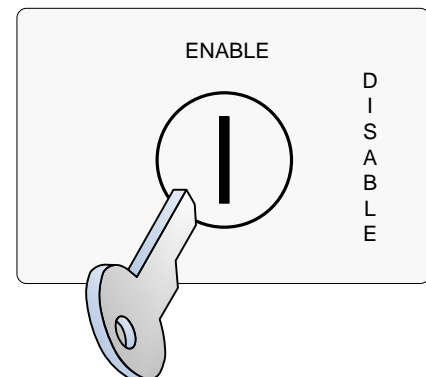

<b>Solenoid Compatibility List</b>			
<b>Manufacturer</b>	<b>Model Number</b>	<b>Standby Current (Amps)</b>	<b>Alarm Current</b>
ASCO	8210G207	0mA	44mA
Parker/Skinner	73218BN4UNLVNOC111C2	0mA	42mA

**Maintenance:** A maintenance agreement should be arranged through the local manufacturer's representative and maintenance should be performed annually by authorized personnel only. To keep a preaction system in excellent working order, ongoing maintenance is required per the manufacturer's recommendations and UL and NFPA standards. At a minimum the requirements of Chapter 13 of NFPA 25 (2010) shall be followed.

**Test Weekly:** The preaction system should be tested weekly to make sure SOM-R, FRCME and SOM-R-DS (Bypass Keyswitch) are working properly. The most common cause of an alarm system not functioning when a fire occurs is inadequate maintenance.



## 5.16 CZM Conventional Zone Module

The Conventional Zone Module (CZM) connects to the Signal Line Circuit (SLC). The module allows the analog panel to interface and monitor conventional devices such as pull stations and two-wire smoke detectors. The CZM is typically used in retrofit situations where pre-existing conventional zones are removed from a conventional system and then connected to the analog panel for discrete monitoring of that zone. All conventional devices connected to a single CZM are reported as a single input. Status conditions are reported as normal, open or alarm. It supervises the external power supply as well as the entire zone of devices. Refer to the installation instructions included with the CZM for more detailed wiring and installation instructions.

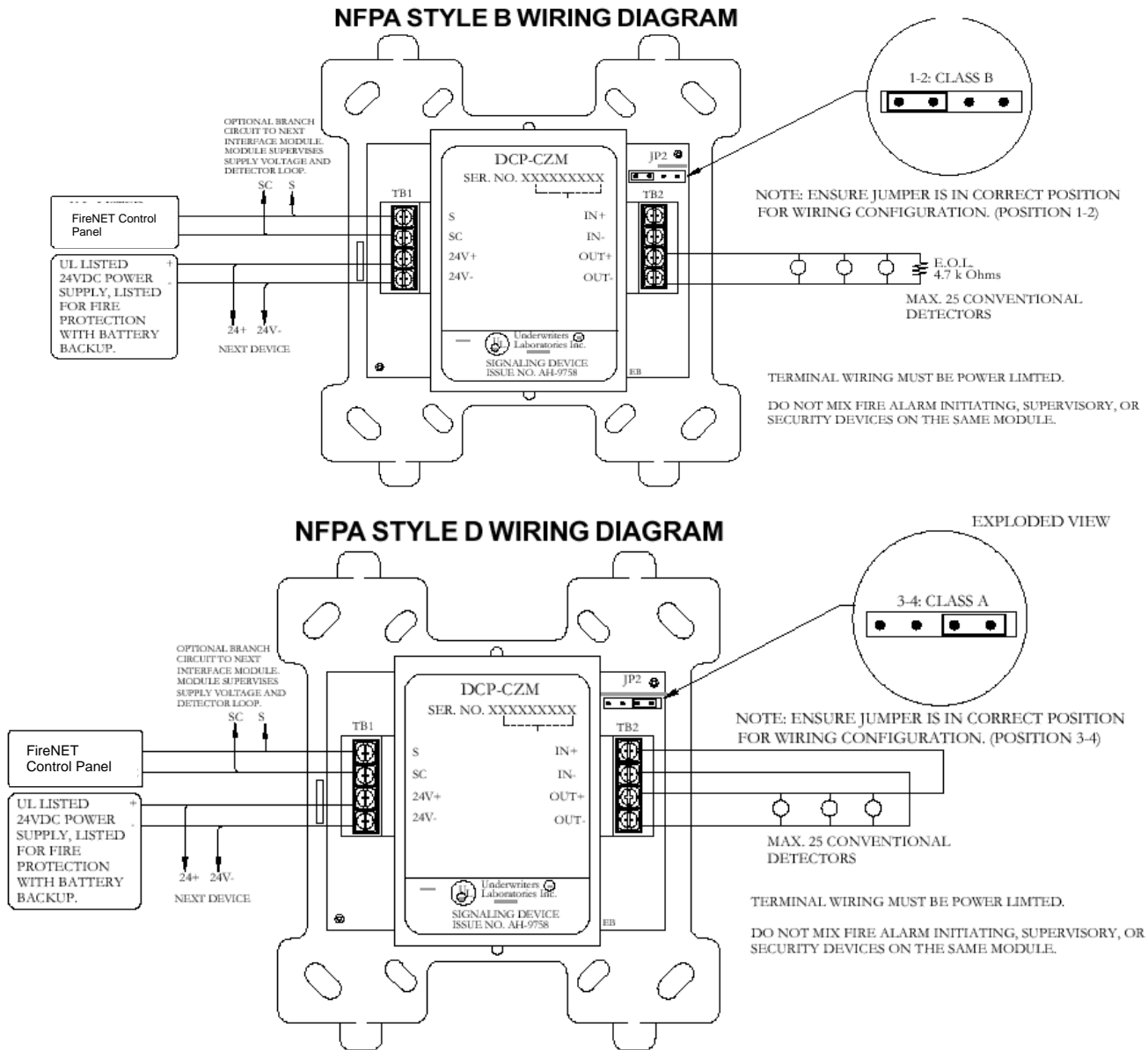

Figure 5.16.1 CZM Conventional Zone Module



## 5.18 SCI Short Circuit Isolator Module

The SCI short circuit isolator module is designed to help maintain partial SLC loop operation in the event that the SLC loop becomes shorted, positive to negative. In the event of an SLC loop short circuit the SLC loop is typically inoperative. By installing SCI modules throughout the SLC loop only a portion of the loop will be inoperative in the case of an SLC short circuit. When SCI modules are installed adjacent to every device for true Style 7 (see Section 5.18.1), no devices are lost from a single short on the SLC loop.

Connect the SCI module to the FireNET 2127/4127 control panel as shown in Figure 5.18.1. Refer to the installation instructions included with each SCI for more detailed wiring and installation instructions.

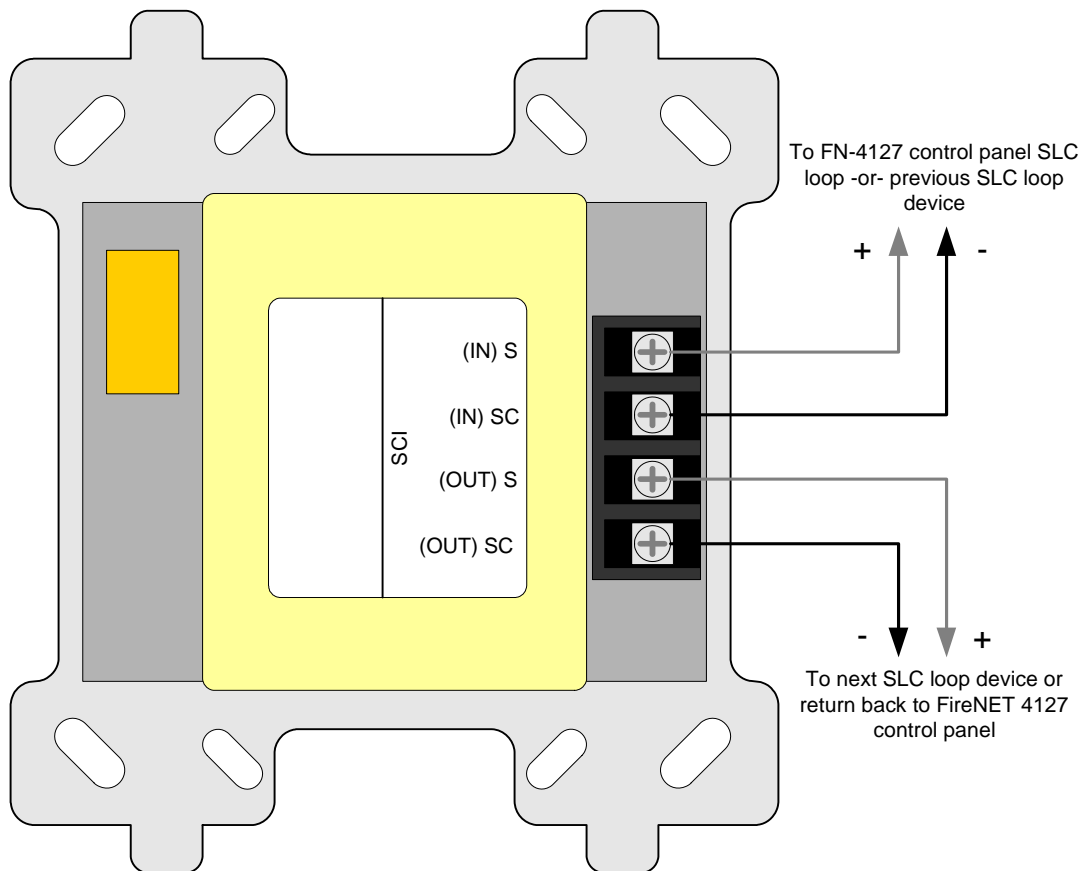

Figure 5.18.1 SCI Module

### 5.18.1 Class A Operation

The SCI should be located within 5 feet of the FN-2127/4127 control panel on both the outgoing and incoming SLC loop legs. In addition an SCI should be located between every SLC loop detector and module as shown in figure 5.18.2 and is required for NFPA 72 Class A Style 7 compliance. For Class A Style 6 compliance the SCI modules may be located at strategic locations based on the installer's or system designer's discretion.

In the event of a short circuit on the SLC loop the 2 adjacent SCI modules to the short (closest SCI on the left and the right of the short) will activate and its LED will turn on. All the devices between the two SCI modules will be isolated and inoperative. All other devices on that SLC loop will remain operational. The FN-2127/4127 control panel will indicate a trouble condition. When installing SCI modules for true Style 7 compliance, the SCI modules must be installed in a "closed nipple" fashion (see Figure 5.18.2). By using this method, no devices are lost from a single short on the SLC Loop.

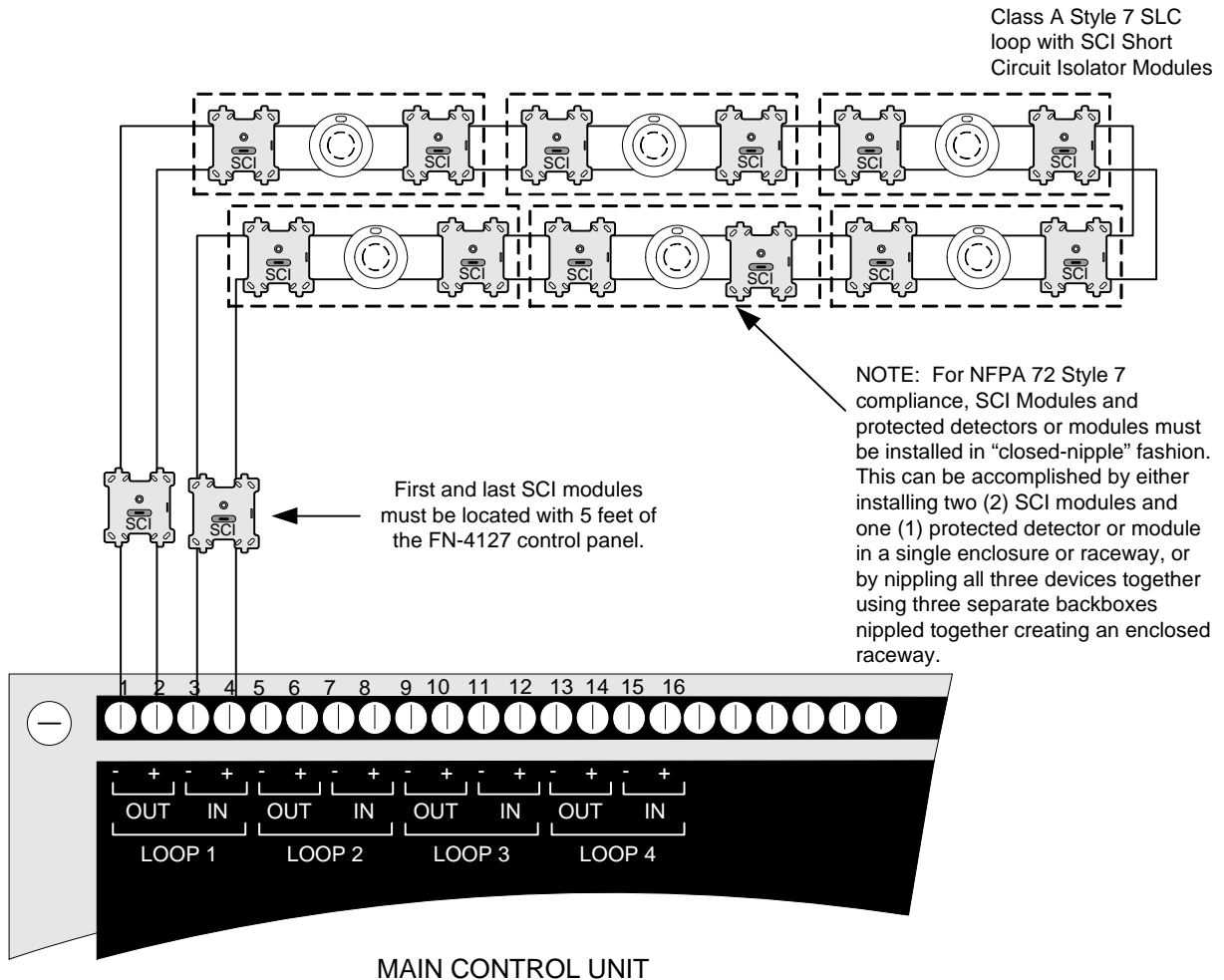

Figure 5.18.2

## 5.18.2 Class B Operation

The SCI modules may be strategically located based on the installer or designer's discretion. Typically they are located at the beginning of each branch of the SLC loop as indicated in figure 5.18.3.

In the event of a short circuit on the SLC loop, the closest SCI to the short circuit will activate and its LED will turn on. All devices following the SCI module will be isolated and inoperative. All devices preceding the SCI module will remain operational.

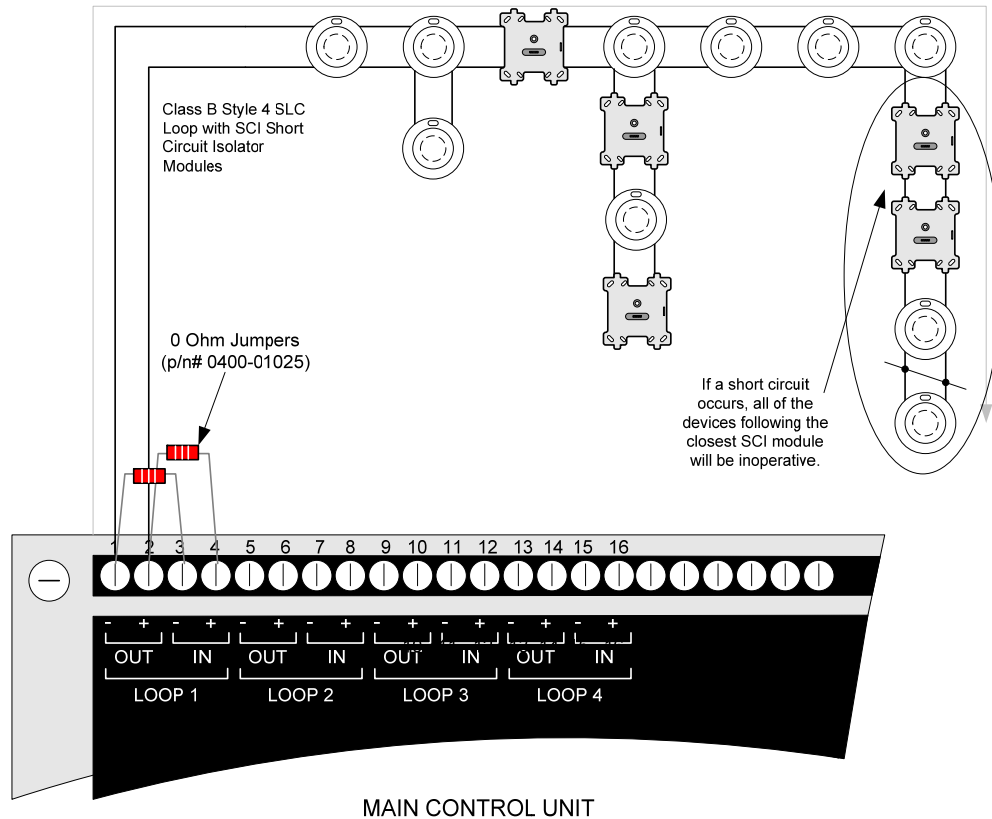
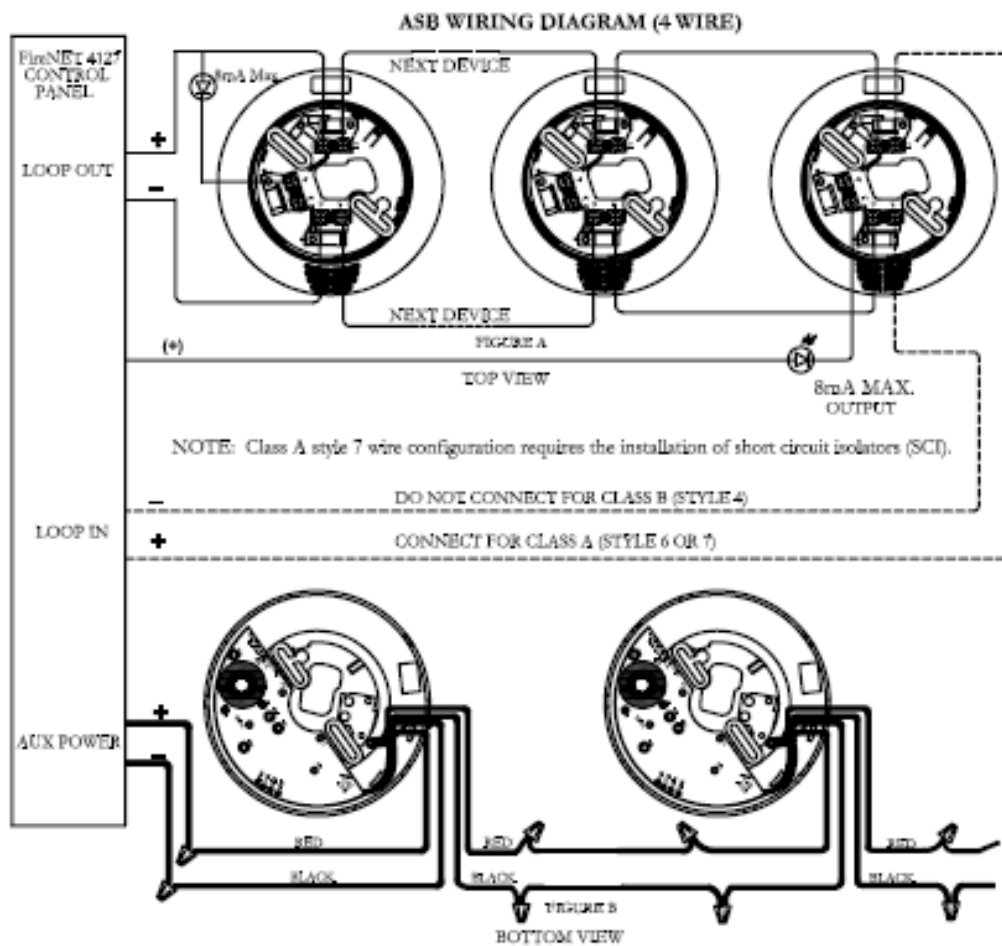

Figure 5.18.3

## 5.19 ASB & ASBL Analog Sounder Base

The Analog Sounder Base (ASB) & Analog Sounder Base Low Frequency (ASBL) connects to the SLC Loop and requires 24VDC aux power to operate. The ASB & ASBL contains an addressable sounder that is controlled by the control panel. The ASB & ASBL derives its address from the Host detector (ALK, ALG, AIE, ATG, ALN, ATJ, ACC and ACA) upon power up. The address is the detector address + 127. See section 5.4 for additional details. The addressable sounder is independently controlled by the control panel, and does not have to follow the detector status to activate.

Refer to the installation instructions included with the ASB & ASBL for more detailed installation and wiring instructions.



## 5.20 AMS Addressable Manual Pull-Station

The AMS Addressable Manual Pull-Station is an integrated device that includes an input module and a manual pull-station in a single package.

The AMS is designed to be directly connected to the FN-2127/4127 control panel SLC loop.

The AMS must be programmed with a unique address between 1 – 127. Each AMS will report individually to the panel based on its unique address. Please refer to Section 5.4 of this manual for instructions on programming an address into the AMS device.

Connect the AMS to the FireNET control panel as shown in Figure 5.20.1. Refer to the installation instructions included with the AMS device for more detailed installation and wiring instructions.

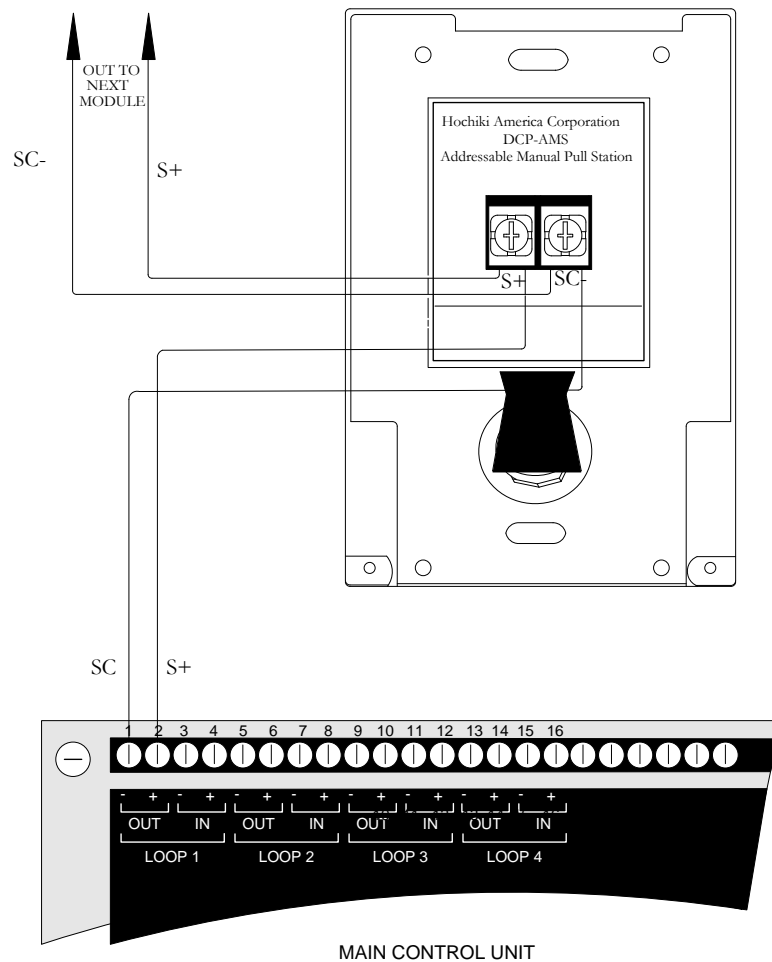

Figure 5.20.1 AMS Addressable Manual Pull Station Wiring Detail

## Section 6 - Network Connections

### ***6.1 Compatible Network Devices***

---

The following Hochiki America Corp. FireNET network devices are listed as compatible with the FireNET 2127/4127 analog addressable fire alarm system.

#### **Network Interface Card**

- FN-4127-NIC

#### **Network Devices**

- FN-LCD-N Network LCD Annunciator

The FireNET system enables information to be transmitted between control panels using a secure network connection. Up to sixty-four control panels and network annunciators (nodes) can be connected together and the system can be configured such that selected information can be displayed or acted upon at each panel.



## 6.1.1 FN-4127-NIC Network Interface Card

To enable control panels to be connected together as a network, a network card must be installed in each panel. This card connects to the FN-2127/4127 on the rear of the panel door and is held in position by two M3 screws. The network card is installed in the exact same fashion for the FN-LCD-N Network LCD annunciator.

To install a network card, the AC and battery power must first be switched off and the metal cover over the front panel PCB removed. The network card can then be plugged into the two connectors (J1 and J3) in the bottom right of the main panel PCB and secured in position with the M3 screws.

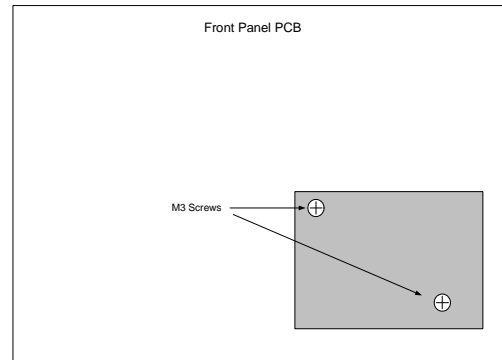

### OBSERVE STATIC PRECAUTIONS WHEN HANDLING CIRCUIT BOARDS

Each network node must be allocated a unique network address. This is done by setting the DIP switches on the network card to the required binary number as shown above. It is important that each panel has a different address for correct operation so care must be taken to set and record the network card address for each panel. Always set the address on the DIP switches with power to the panel **switched off**.

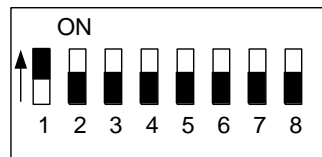

This switch setting shows address number one.

Switch position up selects the binary digit, so a switch with 1,2 and 3 up would represent address number 7.

(The black part shows the switch actuator)

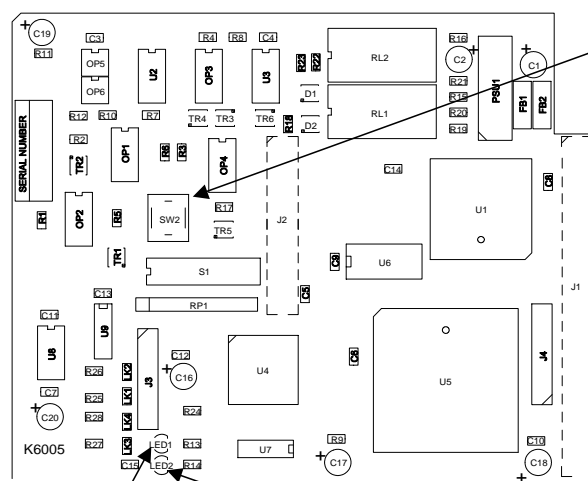

Processor reset switch

LED1-GREEN = OUTGOING CONNECTION OK

LED2-RED = INCOMING CONNECTION OK

This switch setting shows address number one. Switch position up selects the binary digit, so a switch with 1,2 and 3 up would represent address number 7.

The network card has a green and a red LED indicator to show the status of the incoming and outgoing communications. Under normal circumstances, both LEDs will be lit, indicating that the card is communicating properly. If one or both of the LEDs are not lit then the connection to neighboring panels is not functioning properly.

### 6.1.1.1 Cable Length

The FireNET network communications protocol has been designed to be extremely tolerant to interference and data corruption, however as with any system, limitations must be set to guarantee correct operation. The specified transmission distance limit for the communications method used is 4000 ft. (1200m) and because the data is re-transmitted at each network card, in theory, there can be 4000 ft. (1200m) between each card if required. The minimum cable size for the FireNET network is #20 AWG. The network communications uses RS485 technology.

Using the above cable distances however, does not take into account the failure of a network card to communicate with the system through total power failure or a card trouble. In this situation, the network card would disconnect itself from the network and connect the network cable such that it bypasses the card in question. This means that the total cable length between the cards either side of the disconnected one could be 8000 ft. (2400m), which is outside of the specification for the communications method used (RS485). This trouble scenario could clearly be extended to more network cards and this would add 4000 ft. (1200m) of cable length in each case.

A sensible trouble tolerance limit must therefore be suggested to enable the performance of the system to be predicted. Because of the nature of the fire protection system, its design is biased towards inherent reliability and failure of a network card, although possible, is very unlikely. Fire control panels also have substantial back up power systems, therefore, the likelihood of a total power failure under operational conditions, is also extremely rare. A suggested tolerance level of one card failure is therefore recommended. To guarantee operation of the system with one card failure it is necessary to arrange the network so that a failure will not introduce more than 4000 ft. (1200m) of cable between the two cards, which would be connected together by the failure. This means that the total cable length between adjacent nodes should not be more than 4000 ft. (1200m). It is not important how the 4000 ft. (1200 meters) is made up i.e. it could be 350 ft. (100m) and 3650 ft. (1100m) or 2000ft. (600m) and 2000ft. (600m).

Using these general rules and the specified or equivalent cable types will provide a guaranteed performance of networks with plenty of tolerance.

### 6.1.1.2 Wiring Scheme

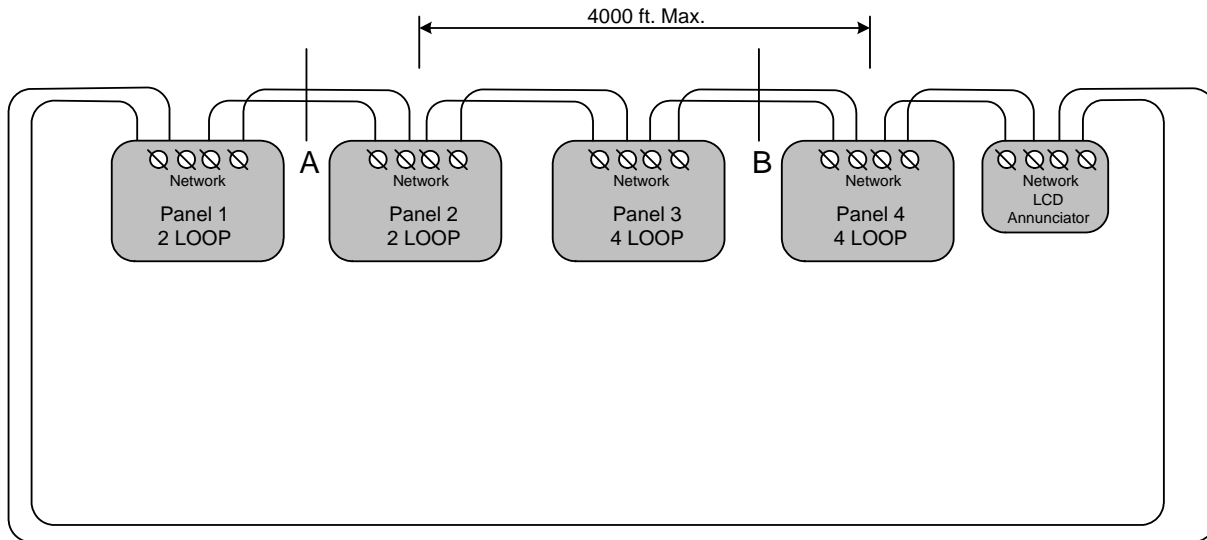

When designing or installing a network of FireNET panels and annunciators, always be aware of the following:

1. The panel network must be wired as a ring.
2. There should be no more than 4000 ft. (1200m) maximum cable length between two adjacent segments.
3. A short circuit at **Point A** should automatically disconnect the shorted section and announce a trouble condition at all panels but the entire network will continue communicating.
4. A short circuit at **Points A and B** should automatically disconnect both sections and announce trouble at all panels. Communication will continue between panels 1 and 4 and between panels 2 and 3.
5. Open circuit troubles should allow the network to continue operating in the same way as short circuit troubles.
6. Network cabling should be standard RS485 type for up to 64 nodes.
7. The minimum cable size for the FireNET network is #20 AWG.

When designing or installing a network of FireNET panels and annunciators using the fiber optic module, always be aware of the following:

1. The panel network must be wired as a ring according to the fiber optic module installation instructions (HA-06-272)
2. A single open circuit between two fiber optic modules will automatically announce a trouble condition at all panels and annunciators, but alarm conditions will only announce at the local panel with the initiated input device (Smoke Detector, Pull Station, etc.)

### **6.1.1.3 Cable Type**

The cable type used for the network connection should be suitable for RS-485 applications. Minimum wire size should be 20ga. twisted, shielded, stranded. RS485 communications cable is typically standard Class 2 communications cable. However, depending on the AHJ, FPL or FPLR cable may be required. Follow local jurisdictional and AHJ requirements. NFPA 70 national electric code compliance may be required for network cabling depending on local jurisdiction, AHJ, regulations, and/or codes.

### **6.1.1.4 Proper Shield Termination of the Network Cable**

In many installations, interference from RFI, EMI or other noise sources can create problems. In order to reduce the effects of such noise, terminate the shield to the earth ground terminal block in the main control panel. **DO NOT** ground the shield at both ends of the cable!

### 6.1.1.5 Connecting the network cable

All panels will have two cables connected to another panel or panels. If either of these is not connected then a trouble will be displayed. The connection is polarity sensitive. The + and – from one panel must connect to the + and – of the next panel and so on. The temperature of the cable should not exceed 131 degrees F (55 C).

**NOTE:** It is important to ensure that the connection from the OUT+ from one panel connects to the IN+ terminal of the next and the OUT- from one panel connects to the IN- of the next panel and so on.

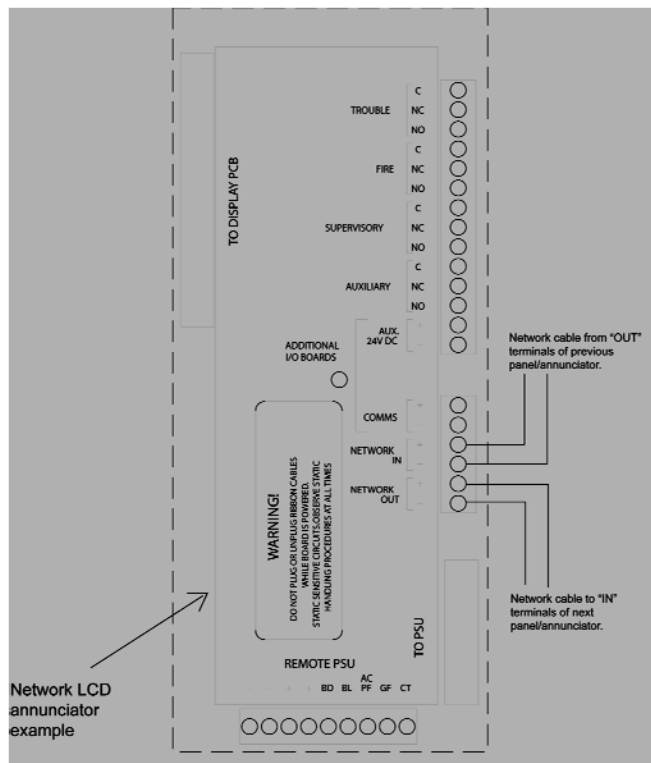
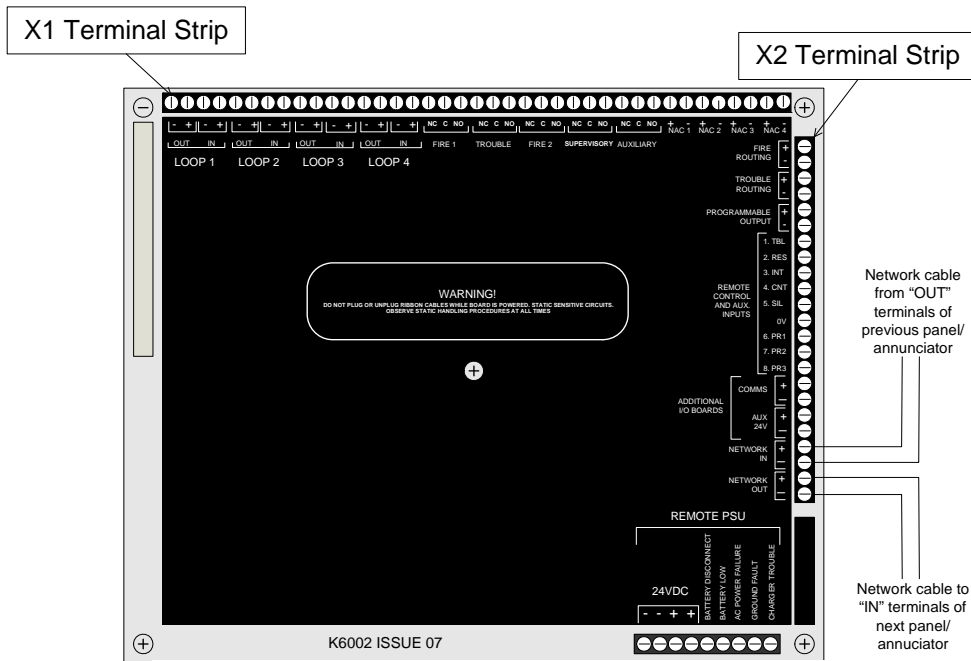

## 6.1.2 FN-LCD-N Network Liquid Crystal Display Annunciator

The FN-LCD-N Network Annunciator duplicates the indications of the FN-2127/4127 fire alarm control panels connected to the same network. The FN-LCD-N connects to the control panel via the network interface and requires that the main control panel have an FN-4127-NIC network card fitted.

The FN-LCD-N Network Annunciator is connected to the network and any number of panels can be connected up to the maximum number of nodes allowed by the network specification, which is 64 (including control panels).

Specific network attributes and routing information from any or all control panels may be assigned to the FN-LCD-N. The LCD display and user interface on the FN-LCD-N operate and indicate in the same manner as the control panel.

The FN-LCD-N is considered a network “node” to the FireNET network just like the control panels.

For operation of the FN-LCD-N please refer to Section 7 of this manual.



**Figure 6.1 FN-LCD-N Network LCD Annunciator**

When powering the FN-LCD-N from the FireNET Aux 24VDC power (limited to 500ma), the following maximum wiring distances apply at the gauges noted:

<u>Wire</u>	<u>Distance</u>
18AWG	925ft
16AWG	1500ft
14AWG	2400ft

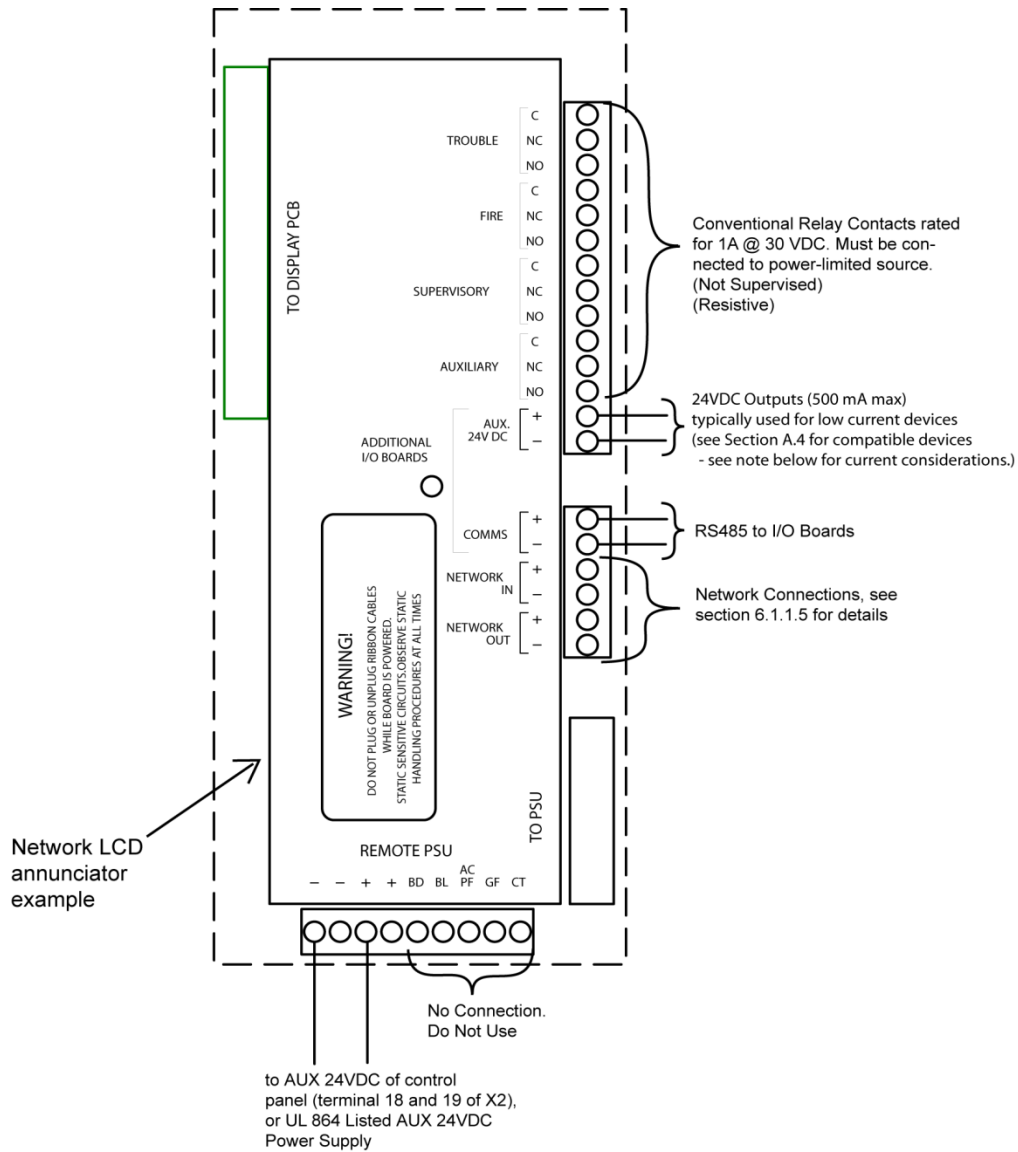

**Figure 6.2 FN-LCD-N Wiring**

**NOTE:** When connecting I/O boards to the FN-LCD-N via the COMMS terminals shown above, the I/O boards must be powered by a UL864 listed local Auxiliary 24VDC power supply, or the Aux 24VDC output of the FN-LCD-N within the limits outlined below.

**DO NOT** connect the I/O board power input to the Aux 24VDC output terminals of the FN-LCD-N unless the sum current load of the I/O board is within the 500ma max 24VDC output rating of the FN-LCD-N and within the 500ma max 24VDC output rating of the FN-2127/4127 control panel that provides power to the FN-LCD-N. Failure to make this consideration may result in overloading the FN-LCD-N and/or the control panel Aux 24VDC output (500ma max. each).

The current limits during both standby and in alarm shall not exceed the 500 mA rating.

Available Colors: RED and CHARCOAL, FN-LCD-N-R = RED, FN-LCD-N-C = CHARCOAL

## Section 7 - Basic Front Panel Operations and Programming (Access Level 1, 2, and Real-Time Operation)

This section covers the basic user operations of the FN-2127/4127 and is intended to provide the casual user a basic understanding of how to complete common system operations. In addition to providing an overview of the front panel controls this section also includes instructions on how to:

- Perform a Lamp Test
- Silence the Panel Sounder
- View Multiple Fire Alarms on the Panel Display
- View Multiple System Events on the Panel Display
- Use the Menu Navigation Buttons
- Use the Help Function
- Silence an Alarm
- Resound an Alarm
- Reset an Alarm
- Initiate a Fire Drill
- Disable Portions of the System
- View the Status of System Devices
- Set system time

All of these operations are performed from the front panel keypad.

Please refer to the front panel photo in Figure 7.1 below while reading through this section.

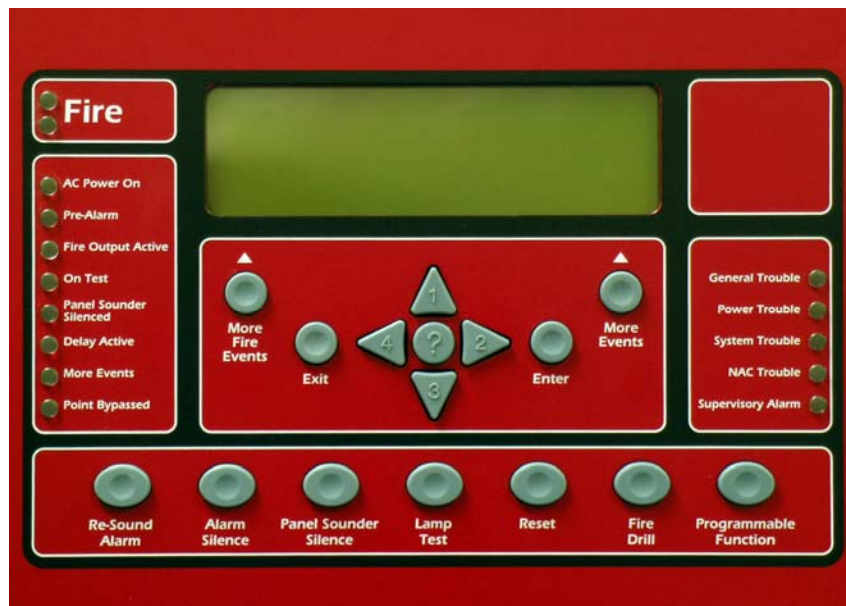

Figure 7.1 Front Panel Control



## ***7.1 Operating Modes***

---

This section provides a brief overview of Access Level 1, 2, and 3 operating modes. Access Level 1 and 2 operating modes are used in the basic system operations described in this chapter. Access Level 3 is typically used only by installation and service personnel and is explained in greater detail in Section 8 of this manual.

### **7.1.1 Access Level 1**

When the FN-2127/4127 control panel is in **Normal Standby** condition only the green **AC Power On** LED will be lit, and the date and time displayed on the LCD display. **Normal Standby** is considered to be in Access Level 1. Some very basic operations can be done in Access Level 1 by simply pushing the corresponding button(s) on the front panel controls. For information on which basic user operations can be done from Access Level 1 see section 7.2.

Note that when using the Denver Door build the control panel buttons are not accessible until the door is opened.

### **7.1.2 Access Level 2**

Many of the front panel controls and their operations require the user to enter a more secure operating mode called Access Level 2. This more secure operating mode prevents unauthorized individuals from operating the FN-2127/4127 fire alarm system. For information on which basic user operations are done from Access Level 2 see section 7.3.

### **7.1.3 Access Level 3**

A higher security mode called Access Level 3 is also available to system administrators, installers, and service personnel to make critical changes to the system. For more information on Access Level 3 refer to Section 8 of this manual. None of the basic operations covered in this section require entry to Access Level 3 operating mode. Access Level 3 operating mode should be restricted to qualified installation and service personnel only.

## ***7.2 Access Level 1 Operations***

---

### **7.2.1 Performing a Lamp Test**

Press the “**Lamp Test**” button on the front panel to illuminate all front panel LED indicators, LCD display, and validate correct operation. Release the button to conclude the test.

## 7.2.2 More Fire Events

The front panel display is capable of displaying the information for up to two different points that are in alarm condition. If more than two points are in an alarm condition simultaneously the front panel display above the “**More Fire Events**” button will indicate how many additional alarms are active. For example the display may indicate “**1 More Fire**”. In this case there is one additional point in fire alarm condition that is not currently shown on the display. By pressing the “**More Fire Events**” button, the user can display these additional alarms.

## 7.2.3 More Events

Similar to the “More Fire Events” button, the “**More Events**” button allows the user to display more non-fire alarm events if more than 2 events are active on the system at one time.

## 7.2.4 Menu Navigation (Up, Down, Left, Right Arrows, Enter / Exit Buttons)

These buttons are used to navigate the FN-2127/4127 menu structure. The arrow buttons (**up, right, down, left**) also represent the digits 1, 2, 3, and 4 respectively when entering codes for Access Level 2 or Access Level 3 modes.

## 7.2.5 Help (?)

The “**Help**” button offers additional information relating to the current status of the FN-2127/4127 control panel and provides assistance in basic operation of the system. Press and hold the “**Help**” button to display this additional information.

Note: When using the Denver Door build of the FireNET panel, the front door of the panel must be opened to perform these commands.

## 7.3 Access Level 2 Operations

---

The following operations can only be done after the panel is placed into Access Level 2 operating mode. To place the FN-2127/4127 into Access Level 2 follow these instructions:

### 7.3.1 Entering Access Level 2

1. Press any navigational arrow key to enable the panel.
2. Using the arrow keys enter the 5 digit code. Digit values are 1 - 4 only and correspond to the value on each arrow key. (Up = 1, Right = 2, Down = 3, Left = 4) The factory default for the Access Level 2 code is 22222.
3. Press the Enter key. The front panel graphic display will confirm you are in Access Level 2.
4. If there is no activity for 120 seconds on the front panel controls once the system is in Access Level 2 operating mode, the system will time out and revert back to Access Level 1 operating mode automatically.
5. You may also use the Enable Access keyswitch on the front door of the panel to enter Access Level 2. Simply insert the key and turn it to the right. The panel display will confirm that you are in Access Level 2.

**NOTE:** The FireNET panel will NOT time out to Level 1 when using the key. Be sure to return the key to the OFF position and remove it when not in use!

When using the Denver Door build of the FireNET panel, opening the enclosure door will put the panel into access level 2 automatically.

### 7.3.2 Silencing an Alarm

To silence an alarm condition place the panel into Access Level 2 operating mode as described in 7.3.1. Press the “**Alarm Silence**” button. The “**Alarm Silence**” button acknowledges any current alarm conditions and typically silences any audible and visual notification appliances such as horns and strobes. In some cases the system may be programmed so that the “Alarm Silence” button silences the audible notification appliances but allows the visual notification appliances such as strobes to remain flashing. Your system installer can inform you how your system is set up to operate. After an alarm has been silenced, the flashing fire LED’s will go steady, and “alarm silenced” will display in the upper right corner of the LCD display.

### 7.3.3 Resounding an Alarm

To resound an alarm condition place the panel into Access Level 2 operating mode as described in 7.3.1. Press the “**Resound Alarm**” button. Pressing the “**Resound Alarm**” button will reactivate any audible or visual notification appliances that were previously silenced using the Alarm Silence operation.

### 7.3.4 Resetting an Alarm

Once a fire or other alarm condition has been verified and cleared it is necessary to reset the panel. To reset the FN-2127/4127; place the panel into Access Level 2 operating mode as described in 7.3.1. Press the “Reset” button. All latched outputs such as relays used for elevator recall will return to their normal state.

Prior to resetting the panel it is necessary to clear the condition that caused the alarm. For example, if a manual pull station was activated to cause the alarm, that manual pull station must be physically reset in order to reset the panel. If you attempt to reset a panel that has an existing alarm condition that has not been cleared, the panel will go back into alarm immediately after trying to reset.

### 7.3.5 Initiating a Fire Drill

To initiate a fire drill place the FN-2127/4127 panel into Access Level 2 operating mode as described in 7.3.1. Press the “Fire Drill” button to engage fire drill mode. The fire drill activates NAC and SOM indication circuits, but does not activate fire relays, R2M, programmable relays, etc. A subsequent press of the fire drill button will deactivate fire drill mode. Any actual fire alarms during a Fire Drill will automatically override fire drill mode.

### 7.3.6 Silence the Panel Sounder

Many system conditions such as system troubles will activate the sounder in the FN-2127/4127 main control panel. The user can silence the panel sounder by pressing the “**Panel Sounder Silence**” button on the front panel. This silences only the panel sounder. Other audible outputs such as horns or strobes require a different operation to silence.

## 7.4 Advanced Access Level 2 Operations

---

### 7.4.1 Access Level 2 Main Menu

Once you have entered Access Level 2 operating mode you can view the Access Level 2 Main Menu, which gives the user the ability to perform additional system operational functions. To view the menu, enter Access Level 2, and then press any one of the navigational arrow keys.

ACCESS LEVEL 2 MAIN MENU
DISABLEMENTS
VIEW DEVICES
TEST ZONES
SET SYSTEM TIME
SENSOR MAINTENANCE EARLY WARNING
ACCESS LEVEL 3

**Table 7.4 Main menu items at Access Level 2**

Once this menu is displayed you can scroll up or down using the navigational arrow keys to highlight each of the six menu options. A menu option is highlighted when a triangular arrow symbol appears to its left.

Each menu option may be selected by first highlighting it using the up/down arrow keys, then pressing the right arrow key to select. The six Access Level 2 Main Menu option functions are described in the following sections.

### 7.4.2 Disablements

The Disablements menu allows the user to disable individual points, circuits, zones, or loops on the FN-2127/4127 fire alarm system. This is typically done while the system is being serviced or tested or to temporarily remove a faulty system device. **CAUTION:** Any portion of the system that is disabled will not report an alarm condition.

All disablements have two options, timed or untimed. For disablements up to 24 hours in length the timed disablement option should be used. This will prompt the user to enter a disablement time in 30-minute increments from 30 minutes to 24 hours. Once the disablement begins the FN-2127/4127 will countdown the selected disablement time. When the time expires the disablement is cancelled automatically.

Untimed disablements should be used only when it is necessary to disable a portion of the system for over 24 hours. Untimed disablements remain active until they are manually reset at the panel through the Access Level 2 Main Menu / Disablements command.

Once you select timed or untimed disablement you can choose to disable loops, zones, addresses, NAC, or I/O circuits through sub-menus to the Access Level 2 Main Menu / Disablements option.

As previously discussed highlighting the desired menu option and then pressing the right navigational arrow selects that option. Pressing the left navigational arrow at any time backs out of the current menu returning to the previous menu.

**Note:** The FN-2127/4127 fire alarm system will indicate a disabled condition any time there is an active disablement on the system, via LCD display text and the “point bypassed” LED on the front panel. Any item disabled is considered an off-normal condition and will generate a common trouble condition until the disabled item is returned to normal.

### 7.4.2.1 Disabling Loops

The Disable Loops sub-menu option to Disablements, allows you to disable an entire SLC loop with one command. The SLC loop may contain up to 127 analog detectors and addressable input and/or output modules, as well as up to 127 analog sounder bases. Disabling an entire SLC loop disables all inputs and outputs on the loop and should be used only in extreme cases such as a service related problem affecting all the devices on the SLC loop.

**WARNING:** Loop disablement does not electrically isolate the panel from the SLC loop wiring. The SLC loop should be disconnected from the panel before any diagnostic testing is performed.

### Disabling Zones

Each device on the system is assigned to a zone by the system installer. Refer to the installation records in Section 11 of this manual for a list of all points on the system and the zones they are assigned to. A zone may consist of one or many points. Disabling a zone disables all the points assigned to that zone.

### Disabling Addresses

Each SLC loop device on the system is assigned a unique address. In some cases an SLC loop device may have sub addresses as well. Using the Disable Address sub-menu command the user can individually disable any single address on the system.

## **Disabling NAC Outputs**

The disable Audible Device output sub-menu option allows the user to disable all of the local NAC, SOM, and ASB outputs on the system. This is typically done for periodic tests so the building occupants are not disturbed while activating each alarm device. When you choose this option all of the notification appliances connected to the panel notification appliance circuits and SOM are disabled, as well as any analog sounder bases.

## **Disable Panel I/O**

The Disable Panel I/O sub-menu option allows a user to disable an individual panel input or output. This includes individual notification appliance (NAC) circuits, on-board panel relays, and the on-board digital inputs. This option applies only to on-board inputs and outputs – SLC loop devices must be disabled by using the Disable Addresses option.

## **View / Restore Disablements**

The View/Restore Disablements sub-menu option is used to quickly display any system disablements and optionally reset them to normal. Scroll to the View/Restore Disablements sub-menu option, press the right navigational arrow to select, and then follow the prompts on the panel display to view/reset any disablements on the system.

### **7.4.3 View Devices**

The View Devices menu option allows the user to view every SLC loop device. For each device the panel display will indicate the device type, zone, and location text. In addition, analog devices such as smoke and heat detectors will also be displayed with their current analog value. This analog value can be useful in determining if a smoke detector requires cleaning. Photoelectric detectors also display in terms of obscuration (%/ft) and the heat detectors in terms of temperature (F°).

For non-analog input devices the current status will be displayed as Off or On. For non-analog output devices the current status will be displayed as either Off or Activated. Service personnel who want to verify system devices and troubleshoot potential problems typically use the View Devices sub-menu option.

### **7.4.4 Test Zones**

The Test Zones sub-menu option is used by service personnel to quickly and easily perform periodic system tests. Please refer to Section 10 of this manual for a more detailed explanation. This feature is typically referred to as a “One Man Walk Test.”

## 7.4.5 Set System Time

This sub-menu option is used to adjust the FN-2127/4127 internal clock. It is important to make sure the clock is accurate so that events logged in the event log are recorded with the correct time.

To set the system clock, select the Set System Time sub-menu option by highlighting it with the up/down arrow keys. Select it by pressing the right arrow key. The resulting menu allows you to individually set the Year, Month, Day, Hour, Minute, and Daylight Savings. Highlight each option by using the up/down arrow keys. Press the right arrow key to select it. Use the up/down arrow keys to change the current values. Pressing the left arrow key in any menu backs you out to the previous menu.

## 7.4.6 Sensor Maintenance Early Warning

This option is used by service personnel to identify sensors that require cleaning or replacement.

## 7.5 Panel Operation

---

This section summarizes the operations described earlier in this section of the manual for handling Fire, Trouble, and Supervisory conditions.

### 7.5.1 Fire Condition

In the event a device on the FN-2127/4127 fire alarm system activates in a fire alarm condition the following will happen:

- Both FIRE LED indicators on the front panel will turn on and flash.
- Details of the device that caused the fire alarm condition will be given in the LCD status display on the front panel.
- If there are more than two fire conditions, press the “**More Fire Events**” button on the front panel to view the additional fire alarms.
- Audible and visual notification appliances (horn and strobes) will activate throughout the building.
- Output relays and circuits will operate performing fire alarm functions such as closing doors, recalling elevators, shutting down air handling equipment etc.
- The panel buzzer will be pulsing.



The operator actions required following a fire alarm condition are as follows:

- Silence the panel buzzer by pressing the “**Panel Sounder Silence**” button.
- Silence the notification appliances by entering Access Level 2 and pressing the “**Alarm Silence**” button. (See section 7.3.1 for instructions on entering Access Level 2). When the Fire condition is silenced, both fire LED indicators change from flashing to steady and the LCD display will indicate “Alarm Silenced”.
- Resound the audible and visual notification appliances if necessary by entering Access Level 2 and pressing the “**Resound Alarm**” button.
- Once the fire department has cleared the building, physically reset any devices such as manual pull stations that require a manual reset.
- Reset the FN-2127/4127 fire alarm control panel by entering Access Level 2 and pressing the “**Reset**” button.

## 7.5.2 Trouble Condition

Trouble conditions occur when problems with the FN-2127/4127 fire alarm system components and wiring are detected.

When the FN-2127/4127 fire alarm control panel senses a trouble condition, the following will occur.

- The General Trouble LED will illuminate on the front panel.
- Other trouble LED's indicating the nature of the trouble may also illuminate.
- The trouble relay contact and voltage output in the control panel will activate
- Details of the trouble condition will be shown on the LCD status display on the front panel.
- If there are two or more trouble events press the “**More Events**” button to view them in the LCD status display on the front panel. (See section 7.3.1 for instructions on entering Access Level 2).
- The panel buzzer will sound.

The operations required following a trouble condition are as follows:

- Press the “Panel Sounder Silence” button to silence the panel buzzer. (See section 7.3.1 for instructions on entering Access Level 2).

- Note the LCD status display and any messages that may appear so these can be relayed to service personnel.
- Investigate the cause of the trouble. It may be as simple as a detector that was inadvertently removed.
- If the trouble condition cannot be resolved, contact your service company.

There is no need to reset trouble conditions. They are non-latching and reset themselves after the trouble condition is corrected.

**NOTE:** Loop Open/Short troubles are latching and require a panel reset to clear.

### 7.5.3 Supervisory Condition

A supervisory condition is detected when a portion of a building system that controls the spread of fire or smoke is disabled. This is most commonly a fire sprinkler valve that is turned off for maintenance purposes.

When the FN-2127/4127 fire alarm control panel senses a supervisory condition the following will occur:

- The Supervisory Alarm LED will illuminate on the front panel.
- The supervisory relay contact in the control panel will activate.
- Details of the supervisory condition will be shown on the LCD status display on the front panel.
- The panel buzzer will sound.

The operations required following a supervisory condition are as follows:

- Press the “Panel Sounder Silence” button to silence the panel buzzer. (See section 7.3.1 for instructions on entering Access Level 2).
- Note the LCD status display and any messages that may appear so these can be relayed to service personnel, fire department, and/or central station.
- Investigate the cause of the supervisory conditions.
- If the supervisory condition cannot be resolved, contact your service company.
- Once the supervisory condition has been cleared, reset the FN-2127/4127 fire alarm control panel by entering Access Level 2 and pressing the “Reset” button.

## 7.5.4 Pre-Alarm Condition

A Pre-Alarm condition occurs when an analog sensor reaches its pre-alarm threshold, or when an input whose type is set to pre-alarm activates. This condition typically occurs as the sensor approaches its fire point.

When the FN-2127/4127 fire alarm control panel senses a pre-alarm condition, the following will occur:

- The Pre-Alarm LED will illuminate on the front panel.
- Details of the pre-alarm condition will be shown on the LCD status display on the front panel.
- If there are two or more events, press the “More Events” button to view them in the LCD status display on the front panel.
- The panel buzzer will sound.

The operations required following a Pre-Alarm condition are as follows:

- Press the “Panel Sounder Silence” button to silence the panel buzzer. (See section 7.3.1 for instructions on entering Access Level 2).
- Note the LCD status display and any messages that may appear so these can be relayed to service personnel.
- Investigate the cause of the Pre-Alarm, such as a significant presence of smoke, heat, or an actual fire starting.
- If the Pre-Alarm condition cannot be resolved, contact your service company.
- Once the Pre-Alarm condition has been cleared, reset the FN-2127/4127 fire alarm control panel by entering access level 2 and pressing the “reset” button.

## Section 8 - Advanced Front Panel Operations and Programming (Access Level 3)

### 8.1 Access Level Overview

The FireNET 2127/4127 has 3 modes of operation. Access Levels 1 and 2 are operational levels that allow the user to perform operational commands such as silencing an alarm or resetting the panel. Access Levels 1 and 2 are explained in further detail in Section 7 - Basic Front Panel Operation and Programming.

Access Level 3 is an installer level operating mode that allows the user to perform some of the basic programming commands used to configure the FN-2127/4127 fire alarm system.

Some of the basic programming functions for the FireNET 2127/4127 control panel can be done from the front panel controls. This section covers the basic programming functions that can be done from the front panel controls of the FN-2127/4127 fire alarm control panel.

#### 8.1.1 Entering Access Level 3

In order to enter Access Level 3 operating mode you must first enter Access Level 2 operating mode. From the Access Level 2 Main Menu you can select Access Level 3.

To enter into **Access Level 3** follow these steps:

1. Press any arrow key to enable the panel.
2. Using the arrow keys enter the 5 digit code for Access Level 2. You can only use digit values of 1-4. The up/down arrow keys represent the values 1-4. Up = 1, Right = 2, Down = 3, and Left = 4. The default Access Level 2 code is 22222
3. Press the Enter key. The front panel graphic display will confirm you are in Access Level 2.
4. Press the right arrow key to access the Access Level 2 Main Menu.
5. Press the down arrow key until **Access Level 3** is highlighted with a triangular arrow to the left of it.
6. Press the right arrow key to select **Access Level 3**.
7. Using the arrow keys enter the 5 digit Access Level 3 code. Digit values are 1-4 only. The default Access Level 3 code is 33333.
8. Press Enter.

Note: If you back out of the Access Level 3 menu using the **Exit** button or the left arrow key, you will have to re-enter the code to go back into Access Level 3 operating mode.

To enter access level 2 when using the Denver Door build of the FireNET panel, it is only necessary to open the front door of the enclosure.

## **8.2 Access Level 3 Menu**

---

Table 8.2 shows the menu structure of the Access Level 3 main menu. You can scroll up and down using the arrow keys to highlight each menu option. Once the option is highlighted with a triangular arrow to the left of it, you can select the option by pressing the right arrow key.

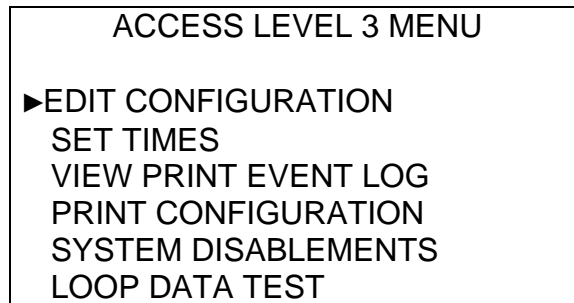

**Access Level 3 Menu Structure**

### **8.2.1 Edit Configuration**

The Edit Configuration menu option displays a sub-menu with even more options to select. Table 8.2.1 indicates these options.

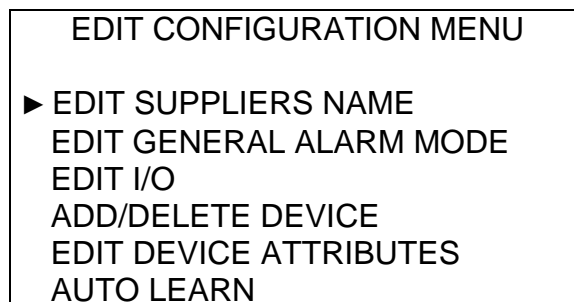

**Edit Configuration Menu Structure**

### **8.2.1.1 Edit Suppliers Name**

The suppliers name is a custom message that is displayed on the front panel LCD status display in normal operation, just under the time/date information at the top of the screen.

The suppliers name can be any text message up to 40 characters long. The default suppliers name message is “Auto Configured Panel”.

From the EDIT CONFIGURATION MENU, highlight “EDIT SUPPLIERS NAME” by using the up down arrow keys then select it by pressing the right arrow key.

Using the left and right arrow keys, select the character you want to edit. Using the up and down arrow keys scroll through available characters that can be used. Refer to the on-screen instructions for additional information.

### **8.2.1.2 General Alarm Mode**

The FN-2127/4127 can be programmed to operate in three different ring modes.

“Common” ring mode activates all audible and visual notification appliance circuits when a fire alarm is activated. This is the default mode of the FN-2127/4127 panel.

“Zonal” ring mode activates only the audible and visual notification appliances that are programmed into the same zone as the device causing the alarm.

Select EDIT GENERAL ALARM MODE from the EDIT CONFIGURATION MENU and use the arrow keys to scroll between “Common” and “Zonal”. Follow the on screen prompts or use the Help (?) button for additional information.

### **8.2.1.3 Edit I/O**

The EDIT I/O menu option allows the user to set the attributes of all the FN-2127/4127 control panel input and output circuits. Selecting EDIT I/O displays a sub-menu giving the user the choice of “Edit Panel I/O” or “Edit Remote I/O”.

#### **8.2.1.3.1 Edit Panel I/O**

##### **Edit Panel Inputs**

Selecting “Edit Panel Inputs” allows the user to scroll between the following panel input circuits. These inputs are utilized by installing a normally open switch contact between Terminal 12, which is 0V, and each input listed below. Please refer to Section 3.6 Digital Inputs for more detail on wiring & limitations of these inputs.

- Trouble Input (Terminal 7)
- Reset Input (Terminal 8)

- Intermittent Input (Terminal 9)
- Continuous Input (Terminal 10)
- Sil. Alarm Input (Terminal 11)
- Programmable Input 1 (Terminal 13)
- Programmable Input 2 (Terminal 14)
- Programmable Input 3 (Terminal 15)
- Programmable Function Button on Front Panel

Each input circuit has the following properties that can be edited. Select each menu option and follow the on screen prompts or press the Help (?) button for further information.

- Zone
  - Selecting this option allows the user to program which software zone the input will be placed in. Default is 0.
- Input Delay
  - Input delays can be programmed (where acceptable by the Authority Having Jurisdiction) in 10-second increments up to 2 minutes.
- Input Latch
  - Each input can be programmed as latching or non-latching. Latching requires the panel to be reset before the condition is cleared. Non-latching resets the condition automatically when the input returns to normal.
- Input Action
  - Input action is the type of event that occurs when the input is activated. Choose between Trouble, Pre-Alarm, Supervisory, Auxiliary, Silence Alarm, Reset, Transparent, Disablement, Test, or Fire.
- Edit Location Text
  - This option allows the user to scroll through the available characters using the arrow keys, and create a custom text message up to 40 characters describing this input.

## **Edit Panel Outputs**

Selecting “Edit Panel Outputs” allows the user to scroll between the following panel output circuits.

- Notification Appliance Circuit 1 (Terminals 32 & 33)
- Notification Appliance Circuit 2 (Terminals 34 & 35)
- Notification Appliance Circuit 3 (Terminals 36 & 37)
- Notification Appliance Circuit 4 (Terminals 38 & 39)
- Fire1 Contact (Terminals 17-19)
- Trouble Contact (Terminals 20-22)
- Fire2 Contact (Terminals 23-25)
- Supervisory Relay (Terminals 26-28) [Not User Programmable]
- Auxiliary Relay (Terminals 29-31)
- Fire Routing Voltage Output (Terminals 1 & 2)
- Trouble Routing Voltage Output (Terminals 3 & 4)
- Programmable Voltage Output (Terminals 5 & 6)

Each output circuit has the following properties that can be edited. Select each menu option and follow the on screen prompts or press the Help (?) button for further information.

- Zone
  - Selecting this option allows the user to program which software zone the input will be placed in. Default is 0.
- Attributes
  - This option allows you to select the output attributes flags for general alarm, silenceable, output, pre-alarm output, trouble output, and Strobe Output. (Strobe option for NAC outputs only).
- Delay Stage 1
  - If you are using staged evacuation. This option sets the delay for stage 1 in 30 second increments up to 5 minutes maximum (Not Available for NAC outputs).
- Delay Stage 2
  - If you are using staged evacuation. This option sets the delay for stage 2 in 30 second increments up to 5 minutes maximum (Not Available for NAC outputs).
- Test Device Output
  - This option allows the output to be manually turned on or off by the user.
- Configure Output as Auxiliary (NAC only)
  - This option allows NAC Outputs to be alternately programmed as power outputs such as constant power, door holder power or resetable power.

**NOTE:** Panel Outputs can be programmed into three primary categories:

- Common
  - When output attribute flags are set for general event categories, the output operation will follow the common activation of that event type. General Alarm mode should be set to “common” for this operation.
- Zone
  - When outputs are assigned to zones, the output operation can be triggered on a zoned basis. General alarm mode should be set to “zonal” for this operation.
- Programmable
  - When outputs are not assigned to general event categories via output attributes, the output operation is programmable by using Cause and Effect.

## Edit Default Pattern

“Edit Default Pattern” allows you to select the on-board NAC circuit output pattern. The available options are Continuous, Temporal and March. The default is Temporal.



## **Edit Alarm Verification**

The alarm verification time value can be set between 5 and 60 seconds. This value must be to 60 seconds to be compliant with UL864 9<sup>th</sup> Edition. Default value is 60 seconds. (See the prefix of this manual for additional details).

## **Edit AC Fail Report Delay**

The AC Fail report delay time value can be set between 0 and 24 hours. Default value is one (1) hour. This value must be set between 1 and 3 hours to be compliant with UL864 9<sup>th</sup> Edition. (See the prefix of this manual for additional details).

### **8.2.1.3.2 Edit Remote I/O**

I/O Board Addresses 1 – 32 can be selected within this menu. Input Channels can be edited within this menu. Programming attributes are the same as described in panel input menu. Output Channels can be edited within this menu. Programming attributes are the same as described in panel output menus. Each I/O board has 16 input/output channels. Each I/O Channel can be selected to be either an input or an output.

### **8.2.1.4 Add/Delete Device**

Selecting the ADD/DELETE DEVICE Menu Option allows the user to add or delete a single SLC loop device to any of the 4 possible SLC loops on the system. To add an SLC loop device using this menu option follow these instructions.

#### **8.2.1.4.1 To Add a SLC Loop Device**

1. Select ADD DEVICE from the EDIT CONFIGURATION MENU by highlighting it, then pressing the right arrow key to select.
2. A sub-menu listing each of the 4 possible SLC loops is displayed. Highlight one of the SLC loops then select it by pressing the right arrow key.
3. Using the up/down arrow keys scroll to the address value that the new SLC loop device is programmed to (1-127 for Sensors and Modules, 128 – 254 for ASB). Only open address values will be displayed which helps to eliminate duplicate address problems. Press the right arrow key to select.
4. Scroll through the list of possible SLC loop devices by using the up/down arrow keys. Press the right arrow key to select.
5. Press the “Enter” button to accept the new device.
6. Follow the prompts on screen or use the Help (?) button for further information.

### **8.2.1.4.2 To Delete a SLC Loop Device**

1. Select the ADD/DELETE DEVICE menu.
2. Using the scroll keys to navigate, select the applicable loop that the device resides on, and then select the device to be deleted.
3. Press the “ENTER” button to perform the deletion.

### **8.2.1.5 Edit Device Attributes**

Selecting EDIT DEVICE ATTRIBUTES from the EDIT CONFIGURATION MENU allows the user to set attributes specific to each SLC loop device on the system. After selecting the SLC loop (1-4) where the device is located, the user can scroll through each SLC device on that loop and set attributes specific to that device.

The device attributes are different for the three different point types - Detector, Input, or Output. Following is a description of the attributes that can be set for each point type.

- Detector (Sensor)
  - Set Zone
    - This option allows the user to set the software zone this device will reside in. Do not use zone 0 for SLC loop devices.
  - Edit Location Text
    - This option allows the user to scroll through and enter up to 40 characters describing the device location
  - Change Sensor Type
    - This option allows you to change the type of sensor currently assigned to this address. Choices are ALK-V Photoelectric, ALG-V Photoelectric Smoke, AIE-EA Ionization Smoke, ATG-EA Heat Sensor, ACA-V Multi Sensor or ALG-DH analog duct sensor.
  - Set Sensitivity
    - This option allows the user to set both the day and night sensitivity levels for this device. Setting the percent per foot obscuration of smoke that must occupy the detectors chamber to cause an alarm, programs smoke detector sensitivity. Setting the temperature that must be reached to cause an alarm (degrees F) programs the heat detector sensitivity. Day and night sensitivity times are configured in another menu location.
  - Set Input Action
    - This option allows the user to change the detector's (sensor) action type to Fire or Supervisory.

- Output Modules (R2M (all models), SOM (all models), ASB and DH98AR Relay)
  - Set Zone
    - This option allows the user to set the software zone this device will reside in. Do not use zone 0 for SLC loop devices.
  - Edit Location Text
    - This option allows the user to scroll through and enter up to 40 characters describing the device location.
  - Delay Stage 1
    - If you are using staged controls. This option sets the delay for stage 1 in 30 second increments up to 5 minutes maximum (R2M modules and DH98AR Relay only).
  - Delay Stage 2
    - If the attribute 'Silenceable' is set to Yes (see below), Delay Stage 2 will become visible. This option sets the delay for stage 2 in 30 second increments up to 5 minutes maximum (R2M modules only).
  - Output Attributes
    - General Alarm mode (Common Fire Alarm): This option allows a user to enable or disable the global General Alarm mode for a selected output(s). When enabled, the output follows the panels General Alarm mode (see 8.2.1.2). When disabled, the output will not follow the General Alarm mode, allowing control by cause and effect logic statements.
    - Silenceable: This option allows a user to program whether the selected output is silenceable via the alarm silence button on the front panel or not (not available for DH98AR/DH-99-AR relay).
    - Pre-Alarm Output: This option allows a user to assign a selected output(s) to the Pre-Alarm Group. When assigned to this group, any sensor going into pre-alarm will cause this output group to activate.
    - Trouble Output: This option allows users to assign a selected output(s) to the Trouble Group. Any input assigned to this group, or any panel trouble will activate all the outputs assigned to this group.
    - Pattern (SOM and ASB only): This option allows the user to select the output pattern for the SOM module. Selections are Continuous, Temporal and March.
    - Test Device Output: This option allows the output to be manually turned on or off by the user.

**NOTE:** Panel Outputs can be programmed into three primary categories:

- Common
    - When output attribute flags are set for general event categories, the output operation will follow the common activation of that event type. General Alarm mode should be set to “common” for this operation.
  - Zone
    - When outputs are assigned to zones, the output operation can be triggered on a zoned basis. General alarm mode should be set to “zonal” for this operation.
  - Programmable
    - When outputs are not assigned to general event categories via output attributes, the output operation is programmable by using Cause and Effect.
- 
- Input Modules (FRCM (all models), DIMM, CZM)
    - Set Zone
      - This option allows the user to set the software zone this device will reside in. Do not use zone 0 for SLC loop devices.
    - Edit Location Text
      - This option allows the user to scroll through and enter up to 40 characters describing the device location.
    - Set Input Delay
      - Input delays can be programmed (where acceptable by the Authority Having Jurisdiction) in 10-second increments up to 2 minutes.
    - Set Input Latch
      - Each input can be programmed as latching or non-latching. Latching requires the panel to be reset before the condition is cleared. Non-latching resets the condition automatically when the input returns to normal.
    - Set Input Action
      - Input action defines the type of event that occurs when the input is activated. Choose between Trouble, Pre-Alarm, Supervisory, Auxiliary, Silence Alarm, Reset, Transparent, Disablement, Test, or Fire.
    - Set Input Type (FRCM and DIMM only)
      - This option allows the programmer to define the type of device being monitored, and if the initiating circuit is configured as normally open or normally closed. Available selections are Pull Station, Waterflow, Valve Monitor N/O, Valve Monitor N/C, Duct Detector, Detector, Reset Alarm, Temperature, Pressure, Level, Position, Power, General Supervision, General Purpose N/O EOL, General Purpose N/C EOL, General Purpose N/C no EOL, and Waterflow Non-Silence. The selected Input Type will appear as part of the message on the LCD display during device activation.

- Test Device Output (LED)
  - This option allows the module LED output to be manually turned on or off by the user. This is helpful for locating installed modules by turned on their indicator.

### 8.2.1.6 Auto Learn

Auto Learn is a utility that can be run to quickly identify and enroll all of the SLC loop devices on the FN-2127/4127 control panel as well as the panel's internal structure and default network routing and nodes.

Auto Learn can be run from the AUTO LEARN sub-menu at any time. When Auto Learn is run, the panel searches each of the 4 possible SLC loops for SLC devices. When it finds a device it identifies which type of device it is, and creates a basic configuration for that device. The installer can then go back and customize the configuration accordingly.

**WARNING:** Running Auto Learn will erase all system programming.

### 8.2.2 Set Times

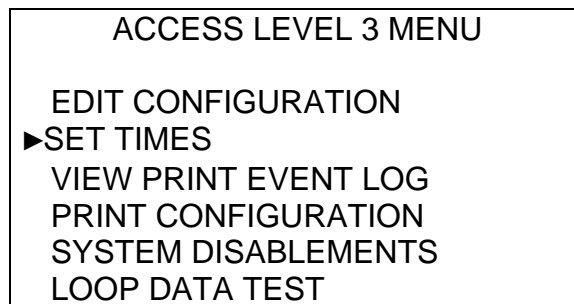

The SET TIMES menu option allows the installer to set the smoke detector calibration time, the day / night sensitivity times, and the Sounder Time-Out for the FireNET panel.

#### 8.2.2.1 Calibration Time

This menu option sets the time of day that the panel will perform calibration on the system smoke detectors. Default is 02:00. The time may be adjusted with the up/down arrow keys. The calibration time should be chosen based on an expected time of day when the environmental conditions in the building are stable.

### 8.2.2.2 Day / Night Times

Day / Night sensitivity is used when you expect environmental conditions to regularly change in the building. By setting the sensitivity lower or higher at certain times of the day or night, false alarms caused by changing environmental conditions may possibly be avoided or reduced.

This menu option allows the installer to program the start and end times for each day of the week for day sensitivity mode. Any times that fall outside of the programmed day start and stop times are considered to be night sensitivity mode.

### 8.2.2.3 Set Sounder Time-Out

This option allows the user to program the NAC circuit activation time during a Fire alarm. At the end of the programmed time, the notification appliance circuits will turn off automatically. Valid selections are from 5 minutes to 60 minutes, in 5-minute increments. The default setting is 0 minutes, which disables the sounder time-out feature.

**NOTE:** This value must be set to zero (0) minutes to be compliant with UL864 9<sup>th</sup> Edition. (See Prefix of this manual for additional details).

### 8.2.3 View Print Event Log

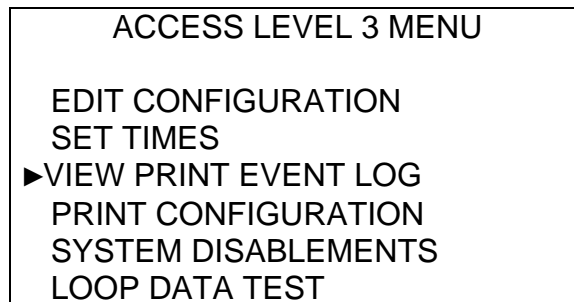

The View Print Event Log menu command allows the user to view the system's 500-event memory log. Any condition outside of normal panel operation generates an entry into the event log. The event log is a very useful tool for troubleshooting system problems or verifying that certain activities, such as Fire Drills, actually took place.

The View Print Event Log menu option is covered in greater detail in Section 10 - Testing and Troubleshooting.

## 8.2.4 Print Configuration

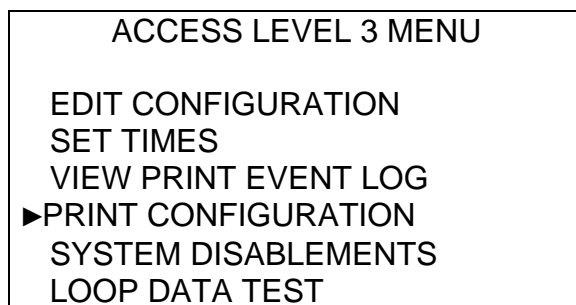

If the system is equipped with a printer, all SLC Loop configuration information can be printed using this menu option. See Section 3.7 for information on adding a printer to the FireNET system.

You can filter the printout by loop or by zone if desired.

## 8.2.5 System Disablements

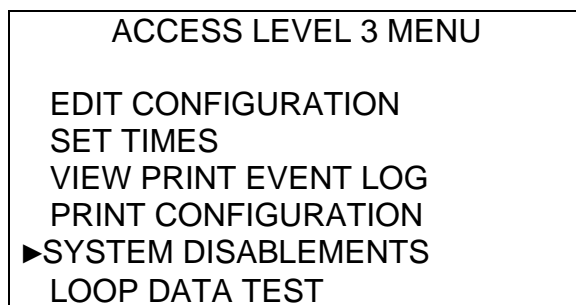

The System Disablements menu option allows the installer to temporarily disable the system printer (if equipped), the panel buzzer, ground fault detection, and set buzzer silence access level. The panel buzzer and ground fault detection are enabled in the panel's default condition. The buzzer silence access level is set to 2 by default.

Disabling any of these options places the panel in a trouble condition. Each disablement of these system devices must be manually reset.

Disabling system devices is typically used on systems where there are intermittent problems, while the problems are being corrected. It is important to note that these features should not be permanently disabled (except printer option). The installer must make sure buzzer and ground fault detection are re-enabled after corrections to the system are complete.

**NOTE:** The following values must be set to be compliant with UL864 9<sup>th</sup> Edition. See prefix of this manual for additional details.

- Buzzer – Enabled
- Ground Trouble – Enabled
- Buzzer Access Level - 2

## 8.2.6 Loop Data Test

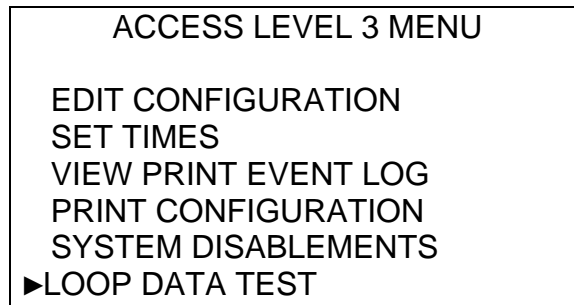

Loop Data Test is an installer or service level diagnostic test that is explained in greater detail in Section 10 - Testing and Troubleshooting.



**Section 9 - Reserved**

## Section 10 - Testing and Troubleshooting

### ***10.1 One Man Walk Test - TEST ZONES***

---

The one-man walk test feature is intended to allow a single service person the ability to test each device without having to reset the panel each time a device is activated. While in test mode, the panel will automatically reset after 3 seconds following any device activation. This allows a service person to activate a device, verify the panel responds by sounding the audible and visual notification appliances, then move on to the next device without going back to the main panel to reset. The Test Zone feature will only activate outputs & devices that are assigned to General Alarm Mode based on the options enabled as described below.

One-man walk test mode is implemented by selecting the TEST ZONES option from the Access Level 2 Main Menu.

Follow these steps to implement a one-man walk test using the TEST ZONES option:

1. Enter Access Level 2 operating mode as described in Section 7.3.1
2. Press the right navigational arrow key to access the Main Menu.
3. Scroll down to highlight the TEST ZONES option.
4. Press the right arrow key to select TEST ZONES.
5. From the Test Zones Menu use the up/down arrow keys to select which zone to test.
6. Press the right navigational arrow key to display the test options.

#### **Local NAC ON - OFF**

Use the up/down arrow keys to select ON or OFF. Setting this option to ON will make all of the audible and visual notification circuits (NAC 1-4) activate for the 3-second duration of each device tested. Setting this option to OFF disables the audible and visual notification appliance outputs during test mode.

#### **Panel Outputs ON-OFF**

Use the up/down arrow keys to select ON or OFF. Setting this option to ON will make all panel relay and voltage outputs function as they have been configured. Setting this option to OFF disables the panel relay and voltage outputs during test mode.

#### **Loop Outputs ON-OFF**

Use the up/down arrow keys to select ON or OFF. Setting this option to ON will activate SLC loop output devices such as SOM modules for audible and visual devices, but will not activate R2M modules. Turning this option to OFF disables the SOM modules during test mode.

Once the test options have been set press “Enter” to start the test or “Exit” to cancel. If you start test mode and want to cancel it anytime within the 15-minute test period, enter Access Level 2 and navigate to TEST ZONES. Enter TEST ZONES and use the right arrow key then Enter to toggle test mode to off.

When a zone is placed into test mode a 15-minute timer is started. If the 15-minute timer expires with no testing done, the test is automatically terminated and the panel is placed back into normal operation. The 15-minute timer is re-started each time a device is tested.

**NOTE** The FN-2127/4127 will be placed in a trouble condition during test mode. The “ON TEST” LED will also illuminate.

## 10.2 View / Print Event Log

---

The View Print Event Log menu command allows the user to view the systems 500-event memory log. Any condition outside of normal operation of the system generates an entry into the event log. The event log is very useful tool for troubleshooting system problems or verifying certain activities such as Fire Drills actually took place.

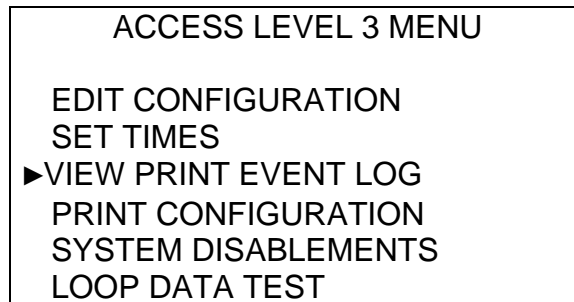

### 10.2.1 View Event Log

To view the event log, you must first enter Access Level 3 (see section 8.1.1). Once in Access Log 3, select VIEW PRINT EVENT LOG. Then select “View Event Log”.

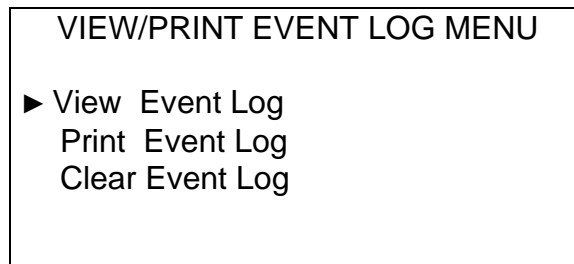

Then select the Event Type Option:

SELECT EVENT TYPES TO VIEW	
Fire	- 4
Pre-Alarm	- 0
► Trouble	- 120
Disablingments	- 0
Other Events	- 94
All Events	- 218

Then select the Individual Events as needed:

VIEW TROUBLE EVENTS 120/120
* TROUBLE:SOM ZONE 02 *
ADR=012.00 LOOP=2 ND=1 AUTOLEARN
TIME 14:35 05/08/2003
Disconnected trouble Cleared
Use UP/DOWN arrow keys to scroll events

### 10.2.2 Print Event Log

To print the event log, you must enter Access Level 3 as noted above (see section 8.1.1). Once in Access Level 3, select VIEW PRINT EVENT LOG. Then select the "Print Event Log".

VIEW/PRINT EVENT LOG MENU
View Event Log
► Print Event Log
Clear Event Log

Then select the Event Type Option

SELECT EVENT TYPES TO PRINT	
► Fire	- 4
Pre-Alarm	- 0
Trouble	- 120
Disablingments	- 0
Other Events	- 94
All Events	- 218

Then press the Enter key to start printing those event types.

PRINT FIRE EVENTS

Press ENTER to start print.

Press EXIT to quit  
Press < to go back.

See Section 3.7 for information on adding a printer to the FireNET panel.

### 10.2.3 Clear Event Log

To clear the event log, you must enter Access Level 3 as noted above (see section 8.1.1). Once in Access Level 3, select VIEW PRINT EVENT LOG. Then select the "Clear Event Log".

VIEW/PRINT EVENT LOG MENU

View Event Log  
Print Event Log  
▶ Clear Event Log

Then press the Enter key to clear the Event Log, or EXIT to cancel.

CLEAR EVENT LOG MENU

Event Log has 218 entries

Press ENTER to clear Event Log.

Press EXIT to quit  
Press < to go back.

## 10.3 Loop Data Test

---

To start the Loop Data Test function, you must first enter Access Level 3 as noted above (see section 8.1.1). Once in Access Level 3, you then must select the Loop Data Test option.

The Loop Data Test Function is a troubleshooting tool that in most cases will never be necessary. When the time does come at that problem job site, the Loop Data Test Function can be easily activated to monitor communication between the FireNET and loop devices. This tool displays the time and date of the test activation, the number of successful and unsuccessful communications on the loop, and the current date and time. The Loop Data Test Function runs in the background and has no affect on the FireNET's ability to perform its intended functions of detection, notification, and control. It is therefore possible to start a Loop Test during a normal business day and let it monitor an individual loop overnight, over a weekend, or during the week. The maximum number of readings is 9,999,999. This will allow a loop to be monitored in excess of one week.

In the event that a large number of bad data readings are received, a review of the installation conditions must be conducted. Possible sources of communications problems are bad wiring, poor wiring practices, large sources of electrical noise (large machines, radio transmitters), improper grounding practices, and the like. When used with good engineering practices, the Loop Data Test Function serves as an integral method to verify loop integrity.

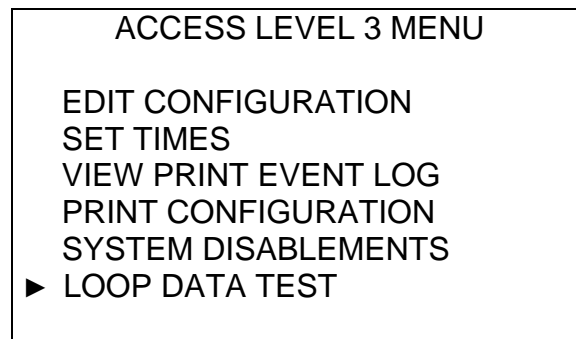

Then select which Loop you wish to test.

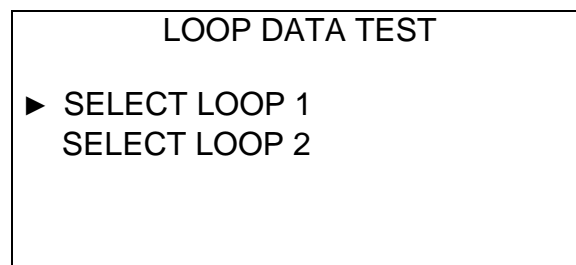

Then select "START TEST".

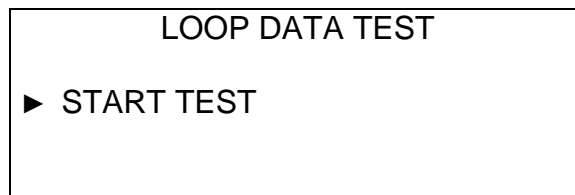

The Loop Data Test result will then display in real time on the screen.

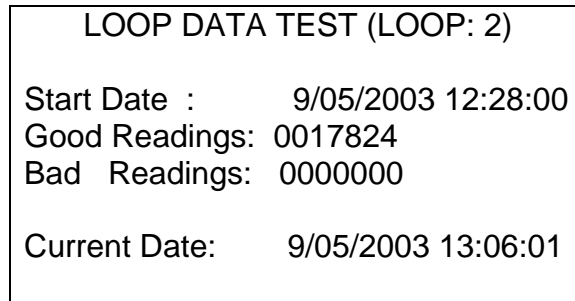

Press the Exit button when the Loop Data Test is completed.

## 10.4 Troubleshooting

---

This section is currently being developed from data collected from installation sites and technical support inquiries.

The following is an example (in FAQ format) of the information being developed:

**Q – I need to change an ALG-V smoke sensor to an ATG-EA heat sensor. Do I have to auto-learn the loops again?**

**A –** No, you can change the device type from smoke sensor to heat sensor. From the Access Level 3 menu choose Edit Configuration then Edit Device Attributes. Select the loop and address of the smoke sensor and then select Change Sensor Type. Select the new sensor type then press Enter. The change will take place immediately.

**Q – My strobes are not flashing correctly when there is an alarm.**

**A –** Check the output pattern; strobes usually require a Continuous (Steady) output pattern. From the Access Level 3 menu choose Edit Configuration then choose Edit I/O. Select Edit Panel I/O, then Edit Default Pattern. Use the up and down arrow keys to highlight the selected pattern, then press the Enter button.

**Q – I am installing analog sounder bases (ASB) on my FireNET panel, but when I do an auto-learn the panel does not find them.**

**A –** Check the firmware revision of the panel. It must be 3.60238 or higher to use the ASB. Also be sure that each ASB is provided with 24 VDC auxiliary power.

**Q – What are the settings for the serial printer port on the FireNET panel?**

**A –** 19,200 baud, 8 data bits, no parity, 1 stop bit.

**Q – I am using the DH-98AR duct detector and I need reset-able aux power. How can I do this?**

**A –** The Auxiliary relay defaults to a reset relay when there is no programming assigned to it. Use the N/C and Common connections of the relay. When the reset button is pressed, the relay will reset power to the devices.



**Q – Can I order extra keys for the FireNET panel?**

**A –** Yes, spare keyswitch models are FN-SKDK/FN-SKCK. Use this part number when ordering; 0100-03380. This includes one key for the door, and one key for the enable keyswitch.

## Section 11 - Installation Records

This section of the manual can be used to record the SLC points, RS485 addresses, and Network nodes you have installed on the system. The tables included in this section can be filled out with this information to be referred back to later for service or troubleshooting purposes. In the near future, all of these tables are available in electronic format from the Hochiki America Corp. web site - [www.hochiki.com](http://www.hochiki.com). These installation records should be filled out for all installations.

### 11.1 SLC Loop Point Record

---

Use the example below to complete the information in Table 11.1 for the SLC loop points on the system:

Loop (1-4)	Address (Sub)	Zone (1-500)	Description	Loop (1-4)	Address (Sub)	Zone (1-500)	Description
1	015	1	(FRCME-P) Main Entry Pull Station	2	015	35	(ATG-EA) Office Closet Heat Detector
	001		N/A		001	N/A	
	002		N/A		002	N/A	
1	016		(R2M Module w/sub addresses)	2	016	35	(ALG-V) Office Smoke Detector
	001	2	Primary Floor Elevator Recall		001	N/A	
	002	3	Secondary Floor Elevator Recall		002	N/A	

### 11.2 RS485 Bus Device Record

---

Use the example below to complete the information in Table 11.2 for the RS485 bus devices installed on the system.

Address (1-32)	Device	Description	Location
1	FN-4127-IO	I/O board used for graphic annunciator driver	FN-2127/4127 Control Panel
2	FN-LCD-S	Local Serial LCD Annunciator	Main Lobby

### 11.3 Network Node Device Record

---

Use the example below to complete the information in Table 11.3 for the Network devices installed on the system.

Node (1-64)	Device	Description	Location
1	FN-4127	FireNET FACP for the main building	South wall of the main entry lobby
2	FN-LCD-N	Remote Network Annunciator for system wide annunciation	Building Engineer's Office

**Table 11.1 FireNET 4127 SLC Loop Point Record**

Loop (1-4)	Address (Sub)	Zone (1-500)	Description	Loop (1-4)	Address (Sub)	Zone (1-500)	Description
	<b>001</b>				<b>001</b>		
	001				001		
	002				002		
	<b>002</b>				<b>002</b>		
	001				001		
	002				002		
	<b>003</b>				<b>003</b>		
	001				001		
	002				002		
	<b>004</b>				<b>004</b>		
	001				001		
	002				002		
	<b>005</b>				<b>005</b>		
	001				001		
	002				002		
	<b>006</b>				<b>006</b>		
	001				001		
	002				002		
	<b>007</b>				<b>007</b>		
	001				001		
	002				002		
	<b>008</b>				<b>008</b>		
	001				001		
	002				002		
	<b>009</b>				<b>009</b>		
	001				001		
	002				002		
	<b>010</b>				<b>010</b>		
	001				001		
	002				002		
	<b>011</b>				<b>011</b>		
	001				001		
	002				002		
	<b>012</b>				<b>012</b>		
	001				001		
	002				002		
	<b>013</b>				<b>013</b>		
	001				001		
	002				002		
	<b>014</b>				<b>014</b>		
	001				001		
	002				002		

Loop (1-4)	Address (Sub)	Zone (1-500)	Description	Loop (1-4)	Address (Sub)	Zone (1-500)	Description
	<b>015</b>				<b>015</b>		
	001				001		
	002				002		
	<b>016</b>				<b>016</b>		
	001				001		
	002				002		
	<b>017</b>				<b>017</b>		
	001				001		
	002				002		
	<b>018</b>				<b>018</b>		
	001				001		
	002				002		
	<b>019</b>				<b>019</b>		
	001				001		
	002				002		
	<b>020</b>				<b>020</b>		
	001				001		
	002				002		
	<b>021</b>				<b>021</b>		
	001				001		
	002				002		
	<b>022</b>				<b>022</b>		
	001				001		
	002				002		
	<b>023</b>				<b>023</b>		
	001				001		
	002				002		
	<b>024</b>				<b>024</b>		
	001				001		
	002				002		
	<b>025</b>				<b>025</b>		
	001				001		
	002				002		
	<b>026</b>				<b>026</b>		
	001				001		
	002				002		
	<b>027</b>				<b>027</b>		
	001				001		
	002				002		
	<b>028</b>				<b>028</b>		
	001				001		
	002				002		

Loop (1-4)	Address (Sub)	Zone (1-500)	Description	Loop (1-4)	Address (Sub)	Zone (1-500)	Description
	<b>029</b>				<b>029</b>		
	001				001		
	002				002		
	<b>030</b>				<b>030</b>		
	001				001		
	002				002		
	<b>031</b>				<b>031</b>		
	001				001		
	002				002		
	<b>032</b>				<b>032</b>		
	001				001		
	002				002		
	<b>033</b>				<b>033</b>		
	001				001		
	002				002		
	<b>034</b>				<b>034</b>		
	001				001		
	002				002		
	<b>035</b>				<b>035</b>		
	001				001		
	002				002		
	<b>036</b>				<b>036</b>		
	001				001		
	002				002		
	<b>037</b>				<b>037</b>		
	001				001		
	002				002		
	<b>038</b>				<b>038</b>		
	001				001		
	002				002		
	<b>039</b>				<b>039</b>		
	001				001		
	002				002		
	<b>040</b>				<b>040</b>		
	001				001		
	002				002		
	<b>041</b>				<b>041</b>		
	001				001		
	002				002		
	<b>042</b>				<b>042</b>		
	001				001		
	002				002		

Loop (1-4)	Address (Sub)	Zone (1-500)	Description	Loop (1-4)	Address (Sub)	Zone (1-500)	Description
	<b>043</b>				<b>043</b>		
	001				001		
	002				002		
	<b>044</b>				<b>044</b>		
	001				001		
	002				002		
	<b>045</b>				<b>045</b>		
	001				001		
	002				002		
	<b>046</b>				<b>046</b>		
	001				001		
	002				002		
	<b>047</b>				<b>047</b>		
	001				001		
	002				002		
	<b>048</b>				<b>048</b>		
	001				001		
	002				002		
	<b>049</b>				<b>049</b>		
	001				001		
	002				002		
	<b>050</b>				<b>050</b>		
	001				001		
	002				002		
	<b>051</b>				<b>051</b>		
	001				001		
	002				002		
	<b>052</b>				<b>052</b>		
	001				001		
	002				002		
	<b>053</b>				<b>053</b>		
	001				001		
	002				002		
	<b>054</b>				<b>054</b>		
	001				001		
	002				002		
	<b>055</b>				<b>055</b>		
	001				001		
	002				002		
	<b>056</b>				<b>056</b>		
	001				001		
	002				002		

Loop (1-4)	Address (Sub)	Zone (1-500)	Description	Loop (1-4)	Address (Sub)	Zone (1-500)	Description
	<b>057</b>				<b>057</b>		
	001				001		
	002				002		
	<b>058</b>				<b>058</b>		
	001				001		
	002				002		
	<b>059</b>				<b>059</b>		
	001				001		
	002				002		
	<b>060</b>				<b>060</b>		
	001				001		
	002				002		
	<b>061</b>				<b>061</b>		
	001				001		
	002				002		
	<b>062</b>				<b>062</b>		
	001				001		
	002				002		
	<b>063</b>				<b>063</b>		
	001				001		
	002				002		
	<b>064</b>				<b>064</b>		
	001				001		
	002				002		
	<b>065</b>				<b>065</b>		
	001				001		
	002				002		
	<b>066</b>				<b>066</b>		
	001				001		
	002				002		
	<b>067</b>				<b>067</b>		
	001				001		
	002				002		
	<b>068</b>				<b>068</b>		
	001				001		
	002				002		
	<b>069</b>				<b>069</b>		
	001				001		
	002				002		
	<b>070</b>				<b>070</b>		
	001				001		
	002				002		

Loop (1-4)	Address (Sub)	Zone (1-500)	Description	Loop (1-4)	Address (Sub)	Zone (1-500)	Description
	<b>071</b>				<b>071</b>		
	001				001		
	002				002		
	<b>072</b>				<b>072</b>		
	001				001		
	002				002		
	<b>073</b>				<b>073</b>		
	001				001		
	002				002		
	<b>074</b>				<b>074</b>		
	001				001		
	002				002		
	<b>075</b>				<b>075</b>		
	001				001		
	002				002		
	<b>076</b>				<b>076</b>		
	001				001		
	002				002		
	<b>077</b>				<b>077</b>		
	001				001		
	002				002		
	<b>078</b>				<b>078</b>		
	001				001		
	002				002		
	<b>079</b>				<b>079</b>		
	001				001		
	002				002		
	<b>080</b>				<b>080</b>		
	001				001		
	002				002		
	<b>081</b>				<b>081</b>		
	001				001		
	002				002		
	<b>082</b>				<b>082</b>		
	001				001		
	002				002		
	<b>083</b>				<b>083</b>		
	001				001		
	002				002		
	<b>084</b>				<b>084</b>		
	001				001		
	002				002		



Loop (1-4)	Address (Sub)	Zone (1-500)	Description	Loop (1-4)	Address (Sub)	Zone (1-500)	Description
	<b>085</b>				<b>085</b>		
	001				001		
	002				002		
	<b>086</b>				<b>086</b>		
	001				001		
	002				002		
	<b>087</b>				<b>087</b>		
	001				001		
	002				002		
	<b>088</b>				<b>088</b>		
	001				001		
	002				002		
	<b>089</b>				<b>089</b>		
	001				001		
	002				002		
	<b>090</b>				<b>090</b>		
	001				001		
	002				002		
	<b>091</b>				<b>091</b>		
	001				001		
	002				002		
	<b>092</b>				<b>092</b>		
	001				001		
	002				002		
	<b>093</b>				<b>093</b>		
	001				001		
	002				002		
	<b>094</b>				<b>094</b>		
	001				001		
	002				002		
	<b>095</b>				<b>095</b>		
	001				001		
	002				002		
	<b>096</b>				<b>096</b>		
	001				001		
	002				002		
	<b>097</b>				<b>097</b>		
	001				001		
	002				002		
	<b>098</b>				<b>098</b>		
	001				001		
	002				002		

Loop (1-4)	Address (Sub)	Zone (1-500)	Description	Loop (1-4)	Address (Sub)	Zone (1-500)	Description
	<b>099</b>				<b>099</b>		
	001				001		
	002				002		
	<b>100</b>				<b>100</b>		
	001				001		
	002				002		
	<b>101</b>				<b>101</b>		
	001				001		
	002				002		
	<b>102</b>				<b>102</b>		
	001				001		
	002				002		
	<b>103</b>				<b>103</b>		
	001				001		
	002				002		
	<b>104</b>				<b>104</b>		
	001				001		
	002				002		
	<b>105</b>				<b>105</b>		
	001				001		
	002				002		
	<b>106</b>				<b>106</b>		
	001				001		
	002				002		
	<b>107</b>				<b>107</b>		
	001				001		
	002				002		
	<b>108</b>				<b>108</b>		
	001				001		
	002				002		
	<b>109</b>				<b>109</b>		
	001				001		
	002				002		
	<b>110</b>				<b>110</b>		
	001				001		
	002				002		
	<b>111</b>				<b>111</b>		
	001				001		
	002				002		
	<b>112</b>				<b>112</b>		
	001				001		
	002				002		
	<b>113</b>				<b>113</b>		
	001				001		
	002				002		

Loop (1-4)	Address (Sub)	Zone (1-500)	Description	Loop (1-4)	Address (Sub)	Zone (1-500)	Description
	<b>114</b>				<b>114</b>		
	001				001		
	002				002		
	<b>115</b>				<b>115</b>		
	001				001		
	002				002		
	<b>116</b>				<b>116</b>		
	001				001		
	002				002		
	<b>117</b>				<b>117</b>		
	001				001		
	002				002		
	<b>118</b>				<b>118</b>		
	001				001		
	002				002		
	<b>119</b>				<b>119</b>		
	001				001		
	002				002		
	<b>120</b>				<b>120</b>		
	001				001		
	002				002		
	<b>121</b>				<b>121</b>		
	001				001		
	002				002		
	<b>122</b>				<b>122</b>		
	001				001		
	002				002		
	<b>123</b>				<b>123</b>		
	001				001		
	002				002		
	<b>124</b>				<b>124</b>		
	001				001		
	002				002		
	<b>125</b>				<b>125</b>		
	001				001		
	002				002		
	<b>126</b>				<b>126</b>		
	001				001		
	002				002		
	<b>127</b>				<b>127</b>		
	001				001		
	002				002		

Table 11.2 RS485 Bus Device Record

Address (1-32)	Device	Description	Location
1			
2			
3			
4			
5			
6			
7			
8			
9			
10			
11			
12			
13			
14			
15			
16			
17			
18			
19			
20			
21			
22			
23			
24			
25			
26			
27			
28			
29			
30			
31			
32			

**Table 11.3 Network Node Device Record**

Node (1-64)	Device	Description	Location
1			
2			
3			
4			
5			
6			
7			
8			
9			
10			
11			
12			
13			
14			
15			
16			
17			
18			
19			
20			
21			
22			
23			
24			
25			
26			
27			
28			
29			
30			
31			
32			

Node (1-64)	Device	Description	Location
33			
34			
35			
36			
37			
38			
39			
20			
41			
42			
43			
44			
45			
46			
47			
48			
49			
50			
51			
52			
53			
54			
55			
56			
57			
58			
59			
60			
61			
62			
63			
64			

These tables may be photocopied if additional pages are necessary.

## Appendix A - Compatible Devices

### A.1 Two-Wire Smoke Detectors

Table A.1 lists the 2-wire smoke detectors that are compatible with the CZM conventional zone module.

**Table A.1: Compatible 2-Wire Smoke Detectors with the Hochiki FireNET CZM Module**

Manufacturer	Model Number	Compatibility ID				Number of Detectors per CZM Module
		Detector	Detector Identifier	Base	Base Identifier	
Hochiki	SLK-24F	Photoelectric	HD-3	HSB-224	HB-53	25
	SIH-24F	Ionization	HD-3	HSB-224	HB-53	25
	SLR-24H	Photoelectric w/ heat	HD-3	NS4-224, NS6-224	HB-5	25
	SLR-24V	Photoelectric	HD-3	NS4-224, NS6-224	HB-5	25
	SLR-835/-835W	Photoelectric (8-35V)	HD-3	NS4-224, NS6-224, NS4-224W, NS6-224W	HB-5	18
	SLR-835H/-835HW	Photoelectric (8-35V) w/ thermal	HD-5	NS4-224, NS6-224, NS4-224W, NS6-224W	HB-5	18
	SLR-835B-2	Photoelectric (8-35V) (baseless)	HD-6	N/A	N/A	18
	SLR-835BH-2	Photoelectric (8-35V) w/ thermal (baseless)	HD-6	N/A	N/A	18
	SIJ-24	Ionization	HD-3	NS4-224, NS6-224	HB-5	25
	DCD-135/-90	Heat Fixed Temp/ Rate of Rise	HD-3	NS4-224, NS6-224	HB-5	25
	DFE-135/-190	Heat Fixed Temp	N/A	HSC -224L	HB-62	25

## A.1.1 Two-Wire Smoke Detectors BOSCH

---

Table A.1.1 lists the 2-wire smoke detectors that are compatible with the CZM conventional zone module.

**Table A.1.1: Compatible 2-Wire Smoke Detectors with the Hochiki FireNET CZM Module**

Manufacturer	Model Number	Detector	Compatibility ID Detector Identifier	Base	Base Identifier	Number of Detectors per CZM Module
BOSCH						
	D283A	Photoelectric w/heat	HD-3	D280A	HB-5	25
	D282A	Photoelectric	HD-3	D280A	HB-5	25
	D265AW	Photoelectric (8-35V)	HD-3	D280AW	HB-5	25
	D281A	Ionization	HD-3	D280A	HB-5	25
	D256A/ D257A	Heat Fixed Temp/Rate of Rise	HD-3	D280A	HB-5	25
	D254/ D255	Heat Fixed Temp	N/A	D253	HB-62	25

## A.2 Reserved for Future Use

---



## **A.3 Compatible Notification Appliances**

---

The A.3 tables list notification appliances that have been verified and listed to be compatible with the FireNET fire alarm control panel per UL864 9<sup>th</sup> Edition.

When **non-synchronized** notification appliances are used on the NAC outputs, they are rated as “**Special Application**” by UL Laboratories. In this case specific device compatibility is not required. For these types of notification appliances the Hochiki 10K end of line resistor PN# 0400-01046 may be used in lieu of the end of line device PN# 0400-01023 if desired.

When **synchronized** notification appliances are used on the NAC outputs, they are rated as “**Special Application**” by UL Laboratories with a range of compatibility from 19.3 ~ 25.95 VDC. In this case specific device compatibility is required as outlined in the tables A.3.1- A.3.3 below. For proper operation use polarized notification appliances with a Hochiki end of line device PN# 0400-01023.

### **NOTE:**

Synchronized audible notification appliances connected to one NAC output are not to be installed within hearing range of the synchronized audible notification appliances on another NAC circuit.

Synchronized visual notification appliances connected to one NAC output are not to be installed within line of site of the synchronized visual notification appliances on another NAC circuit.

### **A.3.1 Amseco/Potter Notification Appliances (24VDC models):**

Per UL864 9<sup>th</sup> edition Special Application testing for worst case strobe loading (synchronized visual notification appliance) is as follows:

Max number of representative devices for worst case in-rush current (SH24W-153075) = 28  
 Max amount of allowable line impedance = 2.5 ohms

Manufacturer	Model Number	Type
<b>AMSECO/POTTER</b>	SMD10-3A	Dual Zone/Daisy Chain Sync Module
	SMS1-3A	Single Zone Sync Module
	TMP Series	Temporal Pattern Module
	SH Series	Select-A-Horn/Strobe Series
	SZ Series	Select-A-Horn/Strobe Series (motor driven horn)
	SL Series	Select-A-Strobe Strobes Series
	H Series	Select-A-Horn Series
	HP Series	Mini-Horn Series
	SAD Series	Stand Alone Strobe Series
	RSD Series	Retrofit Strobe Series
	SLB Series	Outdoor Strobe Series
	SHB Series	Outdoor Horn/Strobe Series
	SHP Series	Select-A-Horn/Strobe Series (mini-horn)
	SSC Series	Select-A-Speaker/Strobe Series
	SFH Series	Select-A-Speaker/Strobe Series (low profile/hi-wattage)
	CM Series	Chime Series
	SCM Series	Select-A-Chime Strobe Series
	MBA Series	Motor Bell Series
	SB Series	Select-A-Bell/Strobe Series
	RSB Series	Retrofit Select-A-Bell/Strobe Series
FS Series	Slow Whoop Sounder Series	
BZ Series	Motor Driven Horn Series	

**NOTE 1:** Please refer to the notification appliance device instructions per the appropriate model and series noted above for specific installation instructions and details required by the manufacturer and UL listing for that device.

**NOTE 2:** Please refer to the sync module instructions per the appropriate model and series noted above for specific installation instructions and details required by the manufacturer and UL listing for that device.

**NOTE 3:** The DCP-SOM-A and DCP-SOM-AI modules are suitable for use with Amseco/Potter notification appliances in both a Class A and Class B configuration with the Amseco/Potter sync module employed.

### **A.3.2 Cooper/Wheelock Notification Appliances (24VDC models):**

Per UL864 9<sup>th</sup> edition Special Application testing for worst case strobe loading (synchronized visual notification appliance) is as follows:

Max number of representative devices for worst case in-rush current (RSS-24MCW) = 41  
 Max amount of line impedance = 2 ohms

Manufacturer	Model Number	Type
<b>COOPER/WHEELLOCK</b>	SM/DSM Series	Sync Modules
	NS Series	Horn/Strobe Series
	NH Series	Horn Series
	AS Series	Audible/Strobe Series
	AH Series	Audible Series
	HS4 Series	Horn/Strobe Series
	HS Series	Horn Series
	MT Series	Multi-tone Horn/Strobes Series
	AMT Series	Multi-tone Horn/Strobes Series
	CH Series	Chimes/Strobe Series
	CSX Series	Explosion Proof Bell Series
	MB Series	Motor Bell Series
	RSS/R/P Series	Strobe Series
	MIZ Series	Mini-Horn Series
	E50/60 Series	Speaker/Strobe Series (high-efficiency)
	E70/90 Series	Speaker/Strobe Series (low profile)
	ET70/90 Series	Speaker/Strobe Series
	ET80/1010/1080 Series	Speaker/Strobe Series (vandal resistant)
	S8 series	Speaker/Strobe Series (8" size)
	STH Series	Cluster Speaker/Strobe Series
	PS Series	NAC Booster Series

**NOTE 1:** Please refer to the notification appliance device instructions per the appropriate model and series noted above for specific installation instructions and details required by the manufacturer and UL listing for that device.

**NOTE 2:** Please refer to the sync module instructions per the appropriate model and series noted above for specific installation instructions and details required by the manufacturer and UL listing for that device.

**NOTE 3:** The DCP-SOM-A and DCP-SOM-AI modules are suitable for use with Cooper/Wheelock notification appliances in both a Class A and Class B configuration with the Cooper/Wheelock sync module employed.

### **A.3.3 Gentex Notification Appliances (24VDC models):**

Per UL864 9<sup>th</sup> edition Special Application testing for worst case strobe loading (synchronized visual notification appliance) is as follows:

Max number of representative devices for worst case in-rush current (GEC3-24WR) = 32  
Max amount of line impedance = 2 ohms

Manufacturer	Model Number	Type
<b>GENTEX</b>	AVSM/AVS-44 Series	Sync Modules
	GCS/GCC Series	Commander 4 Horn/Strobe Series
	GES3/GEC3 Series	Commander 3 Horn/Strobe Series
	GES/GEC/GEH Series	Commander 2 Horn/Strobe Series
	ST/HS Series	Commander 1 Horn/Strobe Series
	WGES/WGEC Series	Weatherproof Horn/Strobe Series
	GB Series	Alarm Bell Series
	GX91/93	Remote Horn Series
	SSPK Series	Speaker/Strobe Series
	SSPKC Series	Speaker/Strobe Series (ceiling mount)
	GE3A/GE3B/GE3G/GE3R Series	Commander 3 Horn/Strobe Series (mass notification)
	GCA/GCB/GCG/GCR Series	Commander 4 Horn/Strobe Series (mass notification)

**NOTE 1:** Please refer to the notification appliance device instructions per the appropriate model and series noted above for specific installation instructions and details required by the manufacturer and UL listing for that device.

**NOTE 2:** Please refer to the sync module instructions per the appropriate model and series noted above for specific installation instructions and details required by the manufacturer and UL listing for that device.

**NOTE 3:** The DCP-SOM-A and DCP-SOM-AI modules are suitable for use with Gentex notification appliances in both a Class A and Class B configuration with the Gentex sync module employed.

### **A.3.4 System Sensor Notification Appliances (24VDC models):**

Per UL864 9<sup>th</sup> edition Special Application testing for worst case strobe loading (synchronized visual notification appliance) is as follows:

Max number of representative devices for worst case in-rush current (P1224MC) = 42  
 Max amount of line impedance = 2 ohms

Manufacturer	Model Number	Type
<b>SYSTEM SENSOR</b>	MDL Series	Sync Modules
	P1224 Series	SpectrAlert Horn/Strobe Series
	S1224 Series	SpectrAlert Strobe Series
	PC24 Series	SpectrAlert Horn/Strobe Series (ceiling)
	SC24 Series	SpectrAlert Strobe Series (ceiling)
	H12/24 Series	SpectrAlert Horn Series
	HC12/24 Series	SpectrAlert Horn Series
	SP2C Series	SpectrAlert Speaker/Strobe Series (ceiling)
	SP2R Series	SpectrAlert Speaker/Strobe Series
	SP2W Series	SpectrAlert Speaker/Strobe Series
	SP3R Series	SpectrAlert Speaker/Strobe Series (hi-output)
	SP3W Series	SpectrAlert Speaker/Strobe Series (hi-output)
	CH24 Series	SpectrAlert Chime/Strobe Series
	CH1224 Series	SpectrAlert Chime Series
	PA400 Series	Mini-Horn Series

**NOTE 1:** Please refer to the notification appliance device instructions per the appropriate model and series noted above for specific installation instructions and details required by the manufacturer and UL listing for that device.

**NOTE 2:** Please refer to the sync module instructions per the appropriate model and series noted above for specific installation instructions and details required by the manufacturer and UL listing for that device.

**NOTE 3:** The DCP-SOM-A and DCP-SOM-AI modules are suitable for use with System Sensor notification appliances in a Class B configuration with the System Sensor sync module employed.

The DCP-SOM-A and DCP-SOM-AI modules are NOT suitable for use with the System Sensor notification appliances when connected to the System Sensor sync module in a Class A configuration.

## A.4 Compatible 24VDC Devices

For proper operation use 24VDC polarized devices. When used on a supervised output or NAC, be sure to use with a Hochiki 10K end of line resistor PN# 0400-01046. When used on the AUX24VDC output the supervision resistor is not necessary.

The AUX24VDC and supervised voltage outputs are rated as **Regulated** by UL Laboratories. In this case specific device compatibility is not required. Be sure to verify current loading of the panel when attaching devices to these outputs by using the battery calculator shown in section 2.6 of this manual.

Table A.4 lists 24VDC devices that are compatible with the FN-2127/4127 fire alarm control panel **Regulated** outputs, though specific compatibility is not required when outputs are rated as **Regulated** by UL.

**Table A.4: Compatible 24VDC Devices with the FN-2127/4127 Fire Alarm Control Panel**

Manufacturer	Model Number	Type
Hochiki America	FN-LCD-N	Network LCD Annunciator
	FN-4127-IO	16 Channel Input Output Board
	SRA-24	Reflective Beam Detector
	SPB-24N	Beam Detector
	FN-LCD-S	Serial LCD Annunciator
	FN-CTM	City-Tie Module
	SOM	Supervised Output Module
	CZM	Conventional Zone Module
	ASB	Analog Sounder Base
	DH-98/99A/AR	Analog Duct Detector
	DH-98P/I/HV	Conventional Duct Detector
	SOM-R	Supervised Output Module-(Pre-Action)
	SOM-A	Supervised Output Module-(Class A)
	SOM-AI	Supervised Output Module-(Class A- w/Isolator)
Bosch	D9068/D7033	Contact Dialer (DACT)/Programmer
Hochiki/Altronix	ULADA Series	NAC Boosters (6, 8, & 10 Amp)
Hochiki/Altronix	ULX Series	AUX 24VDC Power Supplies (2.5, 4, 6, & 10 Amp)
GE/IFS	D1300	RS485 to Fiber Optic Converter (24VDC model)
RSG	DH24 Series	Door Holder Series (24VDC models)

### A.4.1 Compatible 24VDC Devices BOSCH

---

For proper operation use 24VDC polarized devices. When used on a supervised output or NAC, be sure to use with a Hochiki 10K end of line resistor PN# 0400-01046. When used on the AUX24VDC output the supervision resistor is not necessary.

The AUX24VDC and supervised voltage outputs are rated as **Regulated** by UL Laboratories. In this case specific device compatibility is not required. Be sure to verify current loading of the panel when attaching devices to these outputs by using the battery calculator shown in section 2.6 of this manual.

Table A.4.1 lists 24VDC devices that are compatible with the FN-2127/4127 fire alarm control panel **Regulated** outputs, though specific compatibility is not required when outputs are rated as **Regulated** by UL.

**Table A.4.1: Compatible 24VDC Devices with the FN-2127/4127 Fire Alarm Control Panel**

Manufacturer	Model Number	Type
BOSCH	D327A	Supervised Output Module
	D332A/D334A	Analog Duct Detector
	D300A/D300-AHV	Conventional Duct Detector

## A.5 Using the Bosch D9068 Dialer with FireNET

### A.5.1 Using the Bosch D9068 Contact Dialer with FireNET (Diagram)

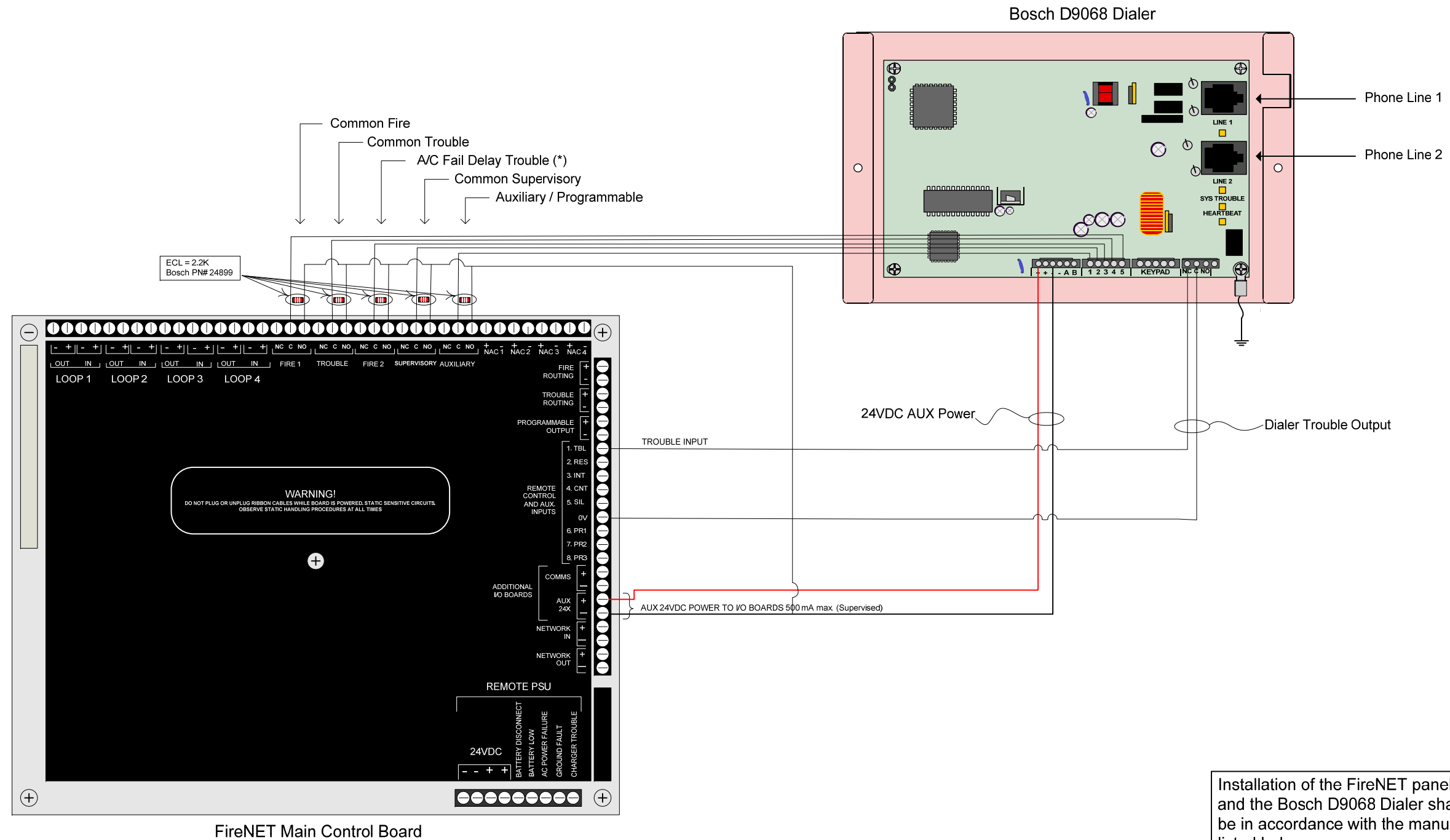

Installation of the FireNET panel and the Bosch D9068 Dialer shall be in accordance with the manuals listed below:

**FireNET Installation Manual**  
Hochiki PN# 1700-09948 Ver. 1.94

**Bosch D9068 O&I Manual**  
Bosch PN# 45386C

## Using the Bosch D9068 Dialer with FireNET

DATE 9/05/2012



## A.5.2 Programming FireNET for use with the Bosch D9068 Dialer

To program the FireNET panel for use with the Bosch D9068 dialer, follow these steps:

1. Program the onboard “Fire 2” relay for “AC Fail Delay” operation:

-> First enable the AC Fail Delay option in the “Access Level 3 \ Edit Configuration \ Edit I/O \ Edit Panel I/O \ Edit Panel Outputs \ Edit Fire 2 Contact” screen:

```
EDIT PANEL OUTPUT ATTRIBUTES MENU
      FIRE 2 CONTACT
>Gen. Alarm Mode   - NO
  Silenceable      - NO
  Emergency Output  - NO
  Pre-alarm Output  - NO
  Trouble Output    - NO
  AC Fail Report    - YES
```

-> Second select an AC Fail Delay time value in the “Access Level 3 \ Edit Configuration \ Edit I/O \ Edit Panel I/O \ Edit AC Fail Report Delay” screen:

```
EDIT AC FAIL REPORT DELAY MENU

AC FAIL REPORT DELAY: 10 hr

Use UP/DOWN arrow keys to set value.
Press ENTER to apply.
Press < to go back. Press EXIT to quit.
```

2. Make sure the panel and outputs listed below are left at the default values in the Panel I/O screens:

- Fire 1 Contact (General Alarm / Common Fire)
- Trouble Contact (Common Trouble)
- Supervisory Output (Common Supervisory)
- Trouble Input (Common Trouble)

3. The auxiliary contact connected to Bosch D9068 Dialer Input #1 is a spare and can be programmed for any function.

1. Input/Output Table:

FireNET Panel	Bosch D9068 Dialer
Fire 1 Relay	Dialer Input 5
Trouble Relay	Dialer Input 4
Fire 2 Relay	Dialer Input 3
Supervisory Relay	Dialer Input 2
Auxiliary Relay	Dialer Input 1
Trouble Input 1	Dialer Trouble Relay Output

### A.5.3 Installation notes when using the Bosch D9068 Dialer with FireNET

**NOTE 1:**

The Bosch D9068 slave contact dialer must be installed within 20ft, in conduit, and within the same room as the FireNET control panel.

**NOTE 2:**

Both the AC Fail Relay in FireNET and the Bosch trigger input assigned to AC Fail functionality have the ability to program an AC Fail Delay time value. The user must choose and program one or the other, not both, or the AC Fail Delay values of each unit will be combined.

**NOTE 3:**

When programming the AC Fail Relay value in FireNET, the value can be set between 0 and 24 hours. UL864 9<sup>th</sup> Edition only recognizes setting this value between 1-3 hours. Setting this value to 0 or between 4 – 24 hours is not in compliance with the UL864 Edition 9 standard. See summary below.

- AC Fail Delay = 1 – 3 hours (complies with UL864 Ed. 9)
- AC Fail Delay = 0, 4 – 24 hours (does not comply with UL864 Ed. 9)

Please see the beginning of this manual for a list of all program settings that can be adjusted outside compliance of the UL864 Edition 9 standard.

## A.6 Using the FN-CTM City Tie module with FireNET

When using the FN-CTM City Tie module for Local Energy City-Tie applications, use the Fire Routing supervised output (see section 3.5). This output by default is programmed for general fire alarm operation.

The supervised NAC outputs of the FireNET panel may also be used. The NAC outputs must be programmed for General Alarm with a Continuous output pattern (see Section 3.4).

Please reference the FN-CTM City Tie module installation instructions included with the module for additional details.

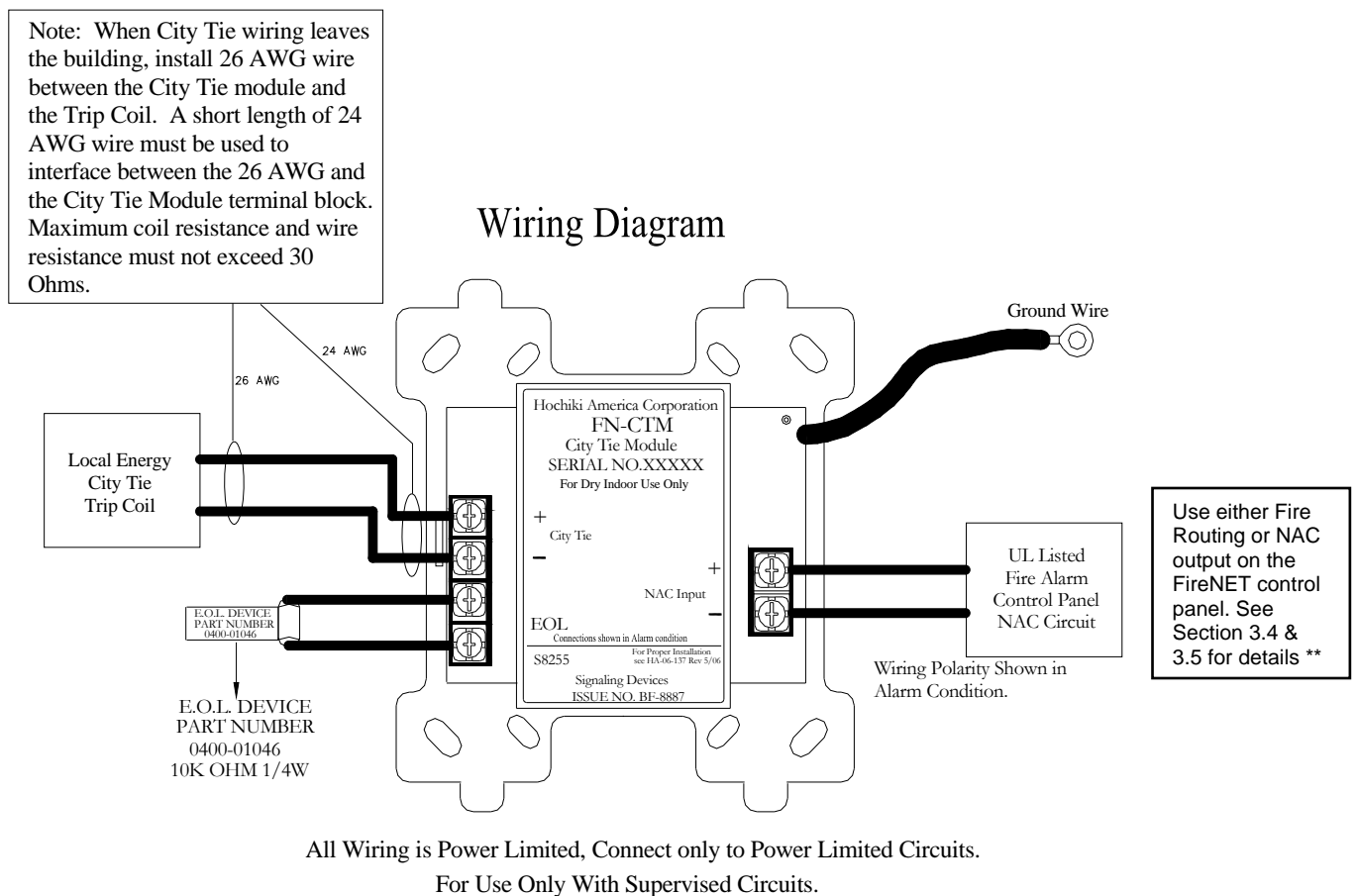

## A.7 Using the FNV-MP with FireNET

When using the FNV-MP with FireNET panel, refer to below wiring diagram. Please reference the installation instructions of the FNV-5010 for all other connection details.

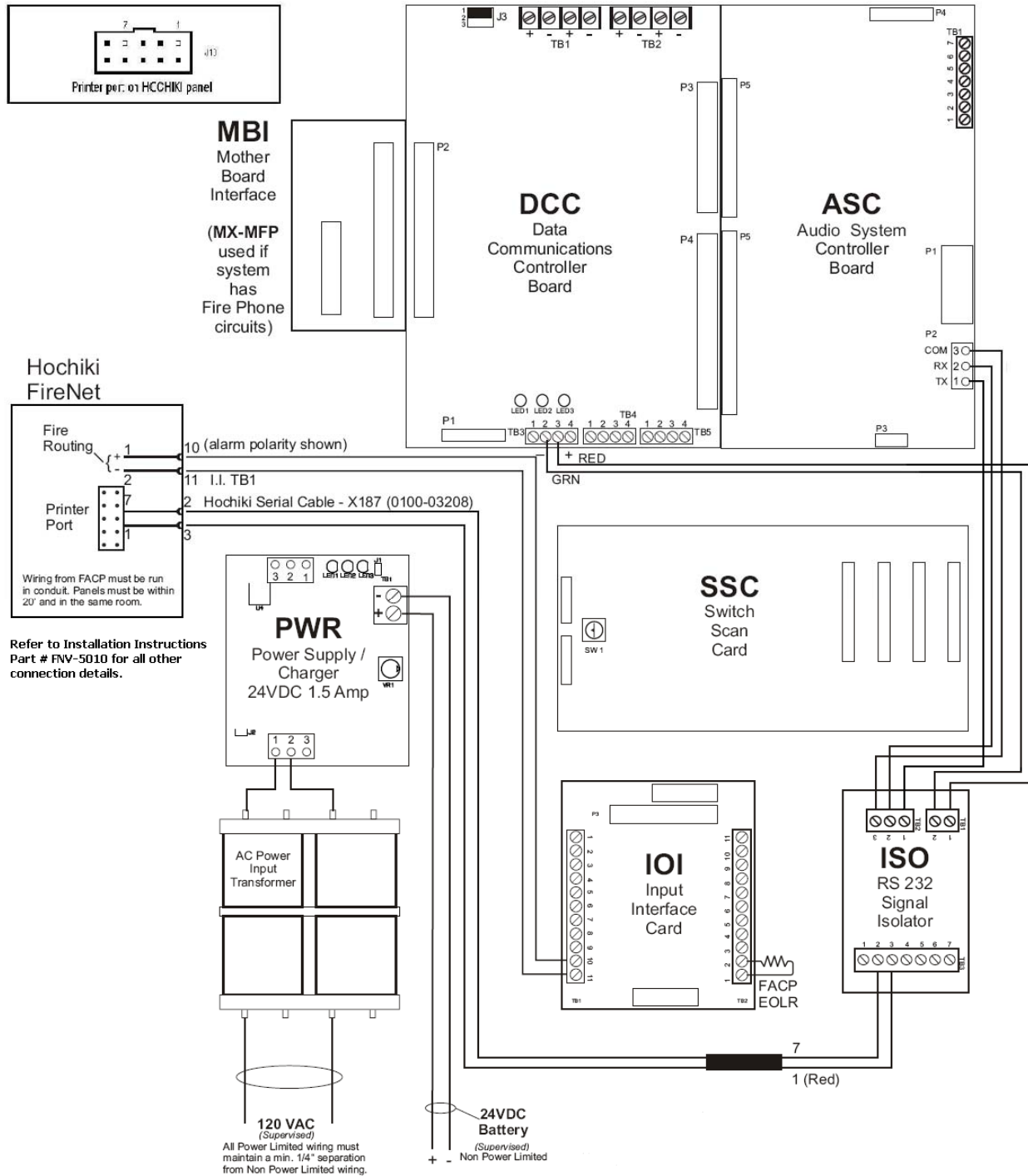

## A.8 Changing the FN-PS402 Power Supply to 240VAC operation

When converting the FN-PS402/FN-PS776 four amp power supply to 240VAC, please follow the directions described in this section. The FN-PS402/FN-PS776 can operate with 120VAC or 240VAC input. By default, the power supply is configured for 120VAC operation. To change it to 240 volts AC, follow the steps below –

- 1) Be sure that the FireNET control panel is NOT powered during this procedure!
- 2) Carefully remove the cover of the power supply.

3) In the upper left hand corner of the circuit board you will see a jumper labeled R72. Remove this jumper from the pins, and re-install the cover. The power supply is now properly configured for 240 VAC operation.



The FN-PS402/FN-PS776 is set for 120VAC operation when the R72 jumper is in place.



The FN-PS402/FN-PS776 is set for 240VAC operation when the R72 jumper is removed.

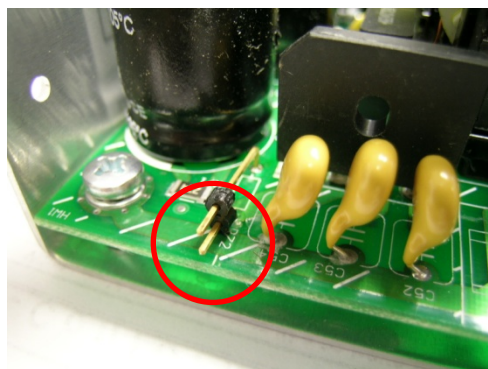

**WARNING** – Do NOT apply 240 VAC to the FireNET control panel unless the power supply has been configured to operate at 240 volts! Doing so will damage the panel, requiring it to be returned to the factory for repair!

## Appendix B – Panel Door Label Drawing

### AGENCY LISTINGS AND REQUIREMENTS

**UL and NFPA Information**  
 Install in accordance with NFPA 70, 72 and 13.  
 The FireNET 4127 is suitable as follows:  
 - Commercial Protected-Premises Control Unit for Local signaling. Install indoors only in a dry environment.  
 - Types of signaling services are automatic, manual, waterflow, & sprinkler supervisory.  
 - Style 4, 8, or 7 for Signaling Line Circuits  
 - Style Y for Notification Appliance Circuits  
 - Non-coded signaling  
 - Central Station Service (DACT)  
 - Remote Station Service (DACT)  
 - UL Releasing Function for Pre-Action with use of SOM-R Module

**Proprietary Service (DACT)**  
 - Auxiliary Service (Local Energy)

**F.C.C. Information**  
 The FireNET 4127 has been verified to comply with FCC Rules Part 15, Class A Operation is subject to the following conditions:  
 1. This device may not cause radio interference.  
 2. This device must accept any interference received, including any that may cause undesired operation.  
 F.C.C. registration number: USHBPAL01BFN-DAC  
**New York City Certificate of Approval #6171**

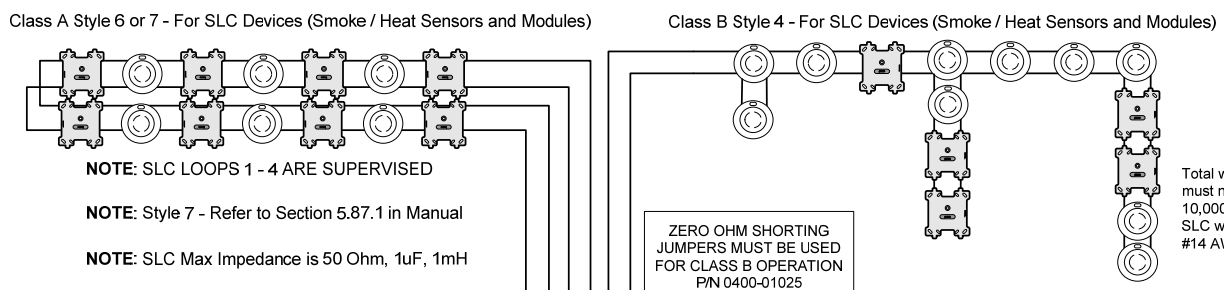

### SLC INITIATING DEVICES

Wire Gauge	Maximum Wire Length for SLC Loop out & return
18 AWG	3900 Feet
16 AWG	6200 Feet
14 AWG	10,000 Feet

**NOTE:** See FireNET Installation Manual as noted below for SLC branch circuit cable requirements

**NOTE:** FireNET employs an option for Sounder Time-Out (for NAC/SOM/ASB), which can be programmed in 5 min. increments between 5-60 min. Option is disabled by setting the value to 0 (default condition).

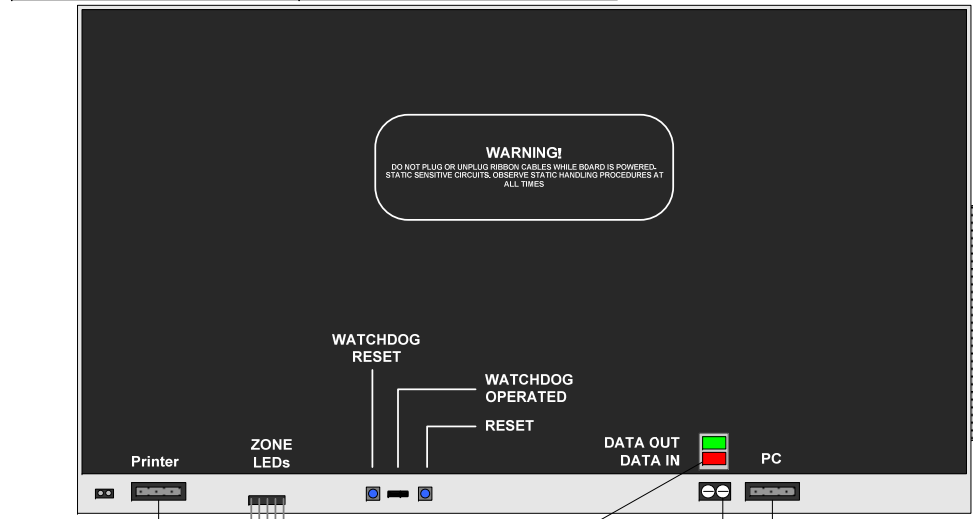

**X1**

PANEL MAY BE CONNECTED TO A REMOTE COMPUTER WITH EMS GRAPHIX CAPABILITY AND USED AS A SUPPLEMENTARY REMOTE ANNUNCIATOR

THE CONNECTION BETWEEN THE PC PORT AND THE COMPUTER MUST BE WITHIN 20 FT IN THE SAME ROOM AND IN CONDUIT.

A DACT INTERFACE MODULE CAN NOT BE USED ON A PANEL/NODE WHICH HAS THIS CONNECTION.

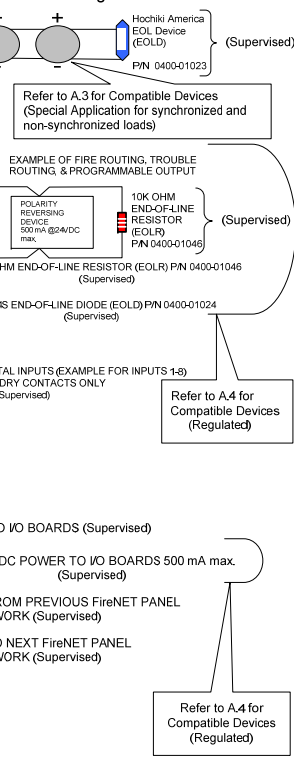
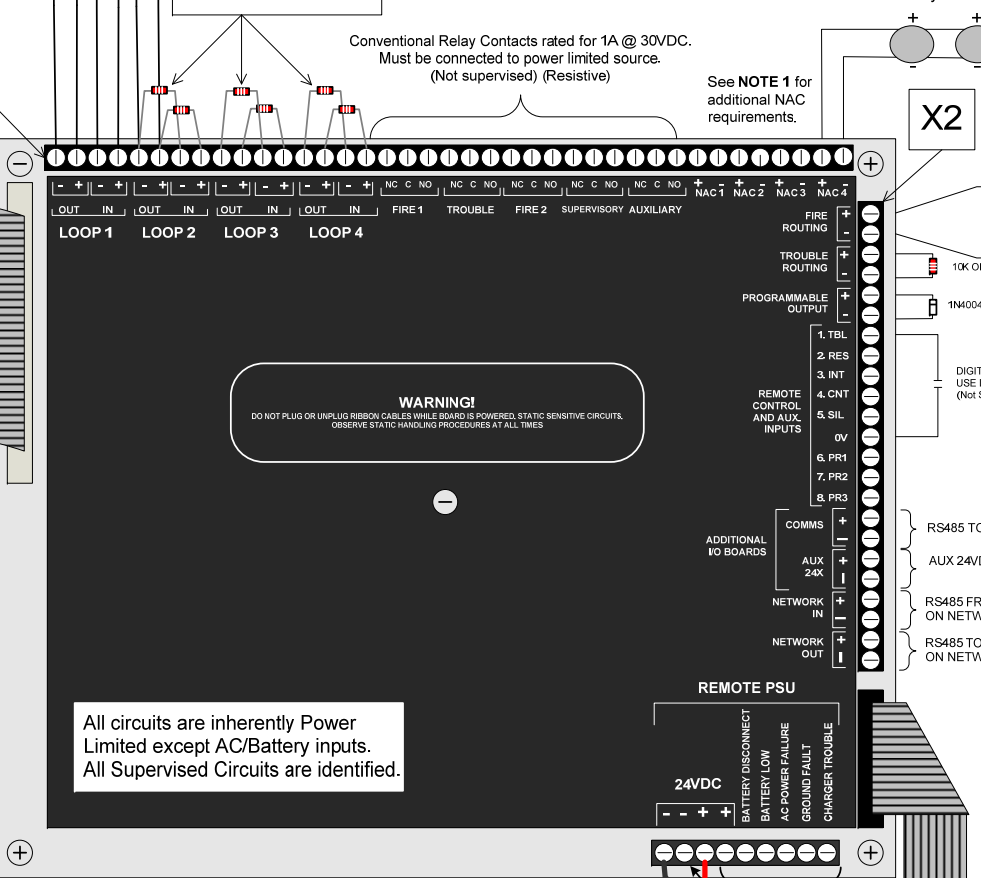

Printer  
Cable must not exceed 20ft. (real-time event logging)

#### TERMINAL STRIP ELECTRICAL RATINGS FOR THE POWER SUPPLY MODULE

Connector	Terminal	Description	Rating	
			Voltage	Current
TB6	G	Earth Ground	N/A	N/A
	N	AC Neutral	120VAC, 50/60Hz	2.1A
	L	AC Line	120VAC, 50/60Hz	2.1A
TB4	+24VDC	+DC Output	+24VDC	0 - 4 Amps
	DC RTN	-DC Output	DC Common	0 - 4 Amps
TB3	+ Battery	+ Battery	+24VDC	5A Max
	- Battery	- Battery	DC Common	5A Max

#### X1 - TOP TERMINAL STRIP ELECTRICAL RATINGS FOR MAIN CONTROL UNIT

Terminal # and Label	Description	Rating	
		Voltage	Current
1, 5, 9, 13	- OUT	32VDC	400mA
2, 6, 10, 14	+ OUT	32VDC	400mA
3, 7, 11, 15	- IN	32VDC	400mA
4, 8, 12, 16	+ IN	32VDC	400mA
17, 20, 23, 26, 29	NC	30VDC	1 A
18, 21, 24, 27, 30	C	30VDC	1 A
19, 22, 25, 28, 31	NO	30VDC	1 A
32, 34, 36, 38	+	24VDC	2.5A
33, 35, 37, 39	-	24VDC	2.5A

#### X2 - SIDE TERMINAL STRIP ELECTRICAL RATINGS FOR MAIN CONTROL UNIT

Terminal # and Label	Description	Rating	
		Voltage	Current
1, 3, 5	+ VOLTAGE OUTPUTS	24VDC	500mA
2, 4, 6	- VOLTAGE OUTPUTS	24VDC	500mA
7, 8, 9, 10, 11, 13, 14, 15	REMOTE/AUX. INPUTS	0VDC	30mA
12	OV DC GROUND	0VDC	500mA
16	+	12VDC	100mA
17	-	12VDC	100mA
18	+	24VDC	500mA
19	-	24VDC	500mA
20, 22	+	12VDC	100mA
21, 23	-	12VDC	100mA

**WARNING**

THIS UNIT INCLUDES AN OPTIONAL ALARM VERIFICATION FEATURE that will result in a delay of the system alarm signal from the indicated circuits. The total delay time (control plus smoke detectors) shall not exceed 60 seconds. No other smoke detector shall be connected to these circuits unless approved by the local Authority Having Jurisdiction.

\*Zone(s)  
\*where alarm verification is used

Programmed Delay is 60 seconds by default. The delay is programmable from 5 - 60 seconds.

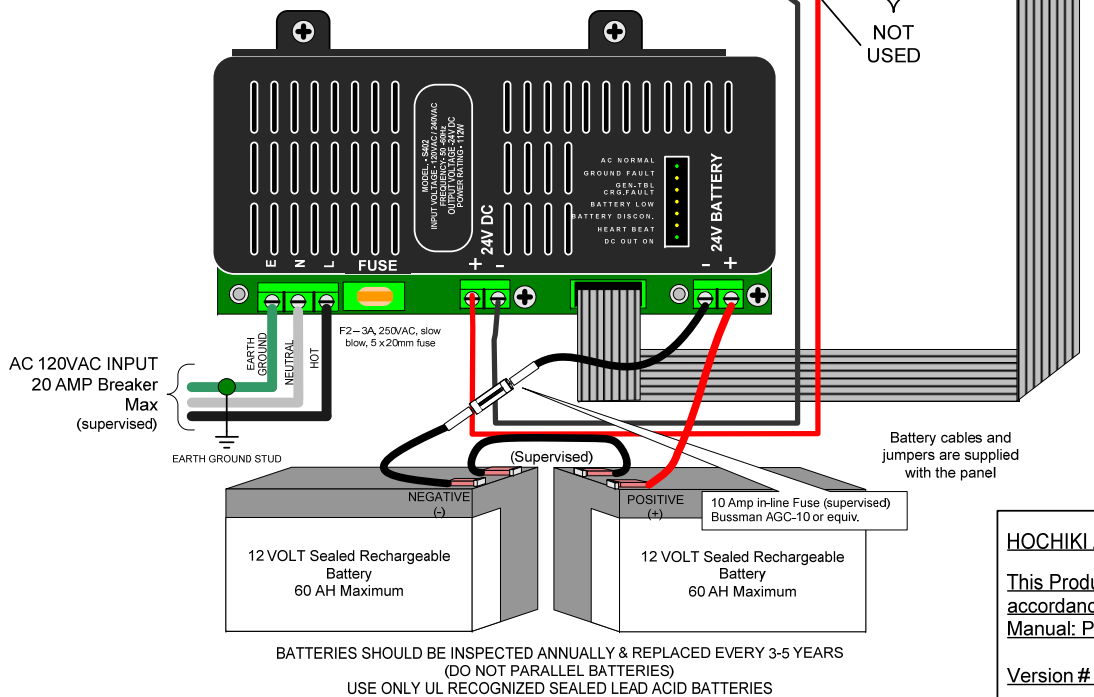

**NOTE 1:**  
(Single Circuit Synchronization)

Synchronized audible notification appliances connected to one NAC output are not to be installed within hearing range of the synchronized audible notification appliances on another NAC circuit.

Synchronized visual notification appliances connected to one NAC output are not to be installed within line of site of the synchronized visual notification appliances on another NAC circuit.

For synchronized NAC applications, the outputs are Special Application with a compatibility range of 19.3 ~ 25.95 VDC.

**HOCHIKI AMERICA CORPORATION**

This Product shall be installed in accordance with FireNET Installation Manual: PN # 1700-09948

Version # 2.03 Issued: Sept 2015

# FireNET WIRING DIAGRAM

P/N 1700-04345 DATE September 2015

## **Appendix C - WARRANTY**

Hochiki America Corporation manufactured equipment is guaranteed to be free from defects in materials and workmanship for a period of three (3) year from date of original shipment. HOCHIKI will repair or replace, at its option, any equipment which it determines to contain defective material or workmanship. Said equipment must be shipped to HOCHIKI prepaid. Return equipment will be prepaid by HOCHIKI. We shall not be responsible to repair or replace equipment which has been repaired by others, abused, improperly installed, altered or otherwise misused or damaged or exposed to conditions outside the products specifications in any way. Unless previously contracted by HOCHIKI, HOCHIKI will assume no responsibility for determining the defective or operative status at the point of installation, and will accept no liability beyond the repair or replacement of the product at our factory service department. Please contact HOCHIKI's Sales department for proper procedure for claims and return of merchandise.

**Hochiki America Corporation  
7051 Village Drive, Suite 100  
Buena Park, CA 90621-2268  
1-800-845-6692  
technicalsupport@hochiki.com**

End of Manual